

\\USER MANUAL

SALTO ESDB | Universal Energy Saver

The Universal Energy Saving Device allows efficient energy control and management in residential and hospitality environments.

The system permits energy to be connected once a person's presence is detected in the controlled area or room.

Universal Energy Saver ESDB

SALTO
inspired**access**



NON - CARD ENERGY SAVER

1. INTRODUCTION	5
2. INSTALLATION	5
3. OPERATION	8
4. CLEANING AND MAINTENANCE	10
5. RESPECTING THE ENVIRONMENT	10

FLUSH MOUNTED MOTION DETECTORS

1. INTRODUCTION	13
2. INSTALLATION	14
3. CLEANING AND MAINTENANCE	16
4. RESPECTING THE ENVIRONMENT	17
5. TECHNICAL DATA	17

SURFACE MOUNTED MOTION DETECTORS

1. INTRODUCTION	21
2. INSTALLATION	22
3. CLEANING AND MAINTENANCE	24
4. RESPECTING THE ENVIRONMENT	25
5. TECHNICAL DATA	25

DOOR/ WINDOW DETECTOR

1. INTRODUCTION	29
2. INSTALLATION	30
3. DETECTOR CONFIGURATION	32
4. CLEANING AND MAINTENANCE	33
5. RESPECTING THE ENVIRONMENT	34
6. TECHNICAL DATA	34

//USER MANUAL

SALTO ESDB | Universal Energy Saver

The ESDB Energy Saving Device allows efficient energy control and management in residential and hospitality environments.

The system permits energy to be connected once a person's presence is detected in the controlled area or room.

Universal Energy Saver Non-card energy saver

SALTO
inspiredaccess





Read the following instructions carefully before installing the product and keep this document for future reference.

General warnings and instructions to ensure the correct operation of the product in your installation:

1. The installation and use of the product must be done in accordance with the instructions included in this document.
2. Correct operation of the unit is the client's responsibility. SALTO is not responsible for any damages resulting from the incorrect use of the product.
3. If a unit has failed to function correctly and/or has been damaged, please contact your SALTO dealer and do not try to repair and reinstall the unit yourself.
4. This device must be used only in indoor environments.



IMPORTANT! Do not expose this device to rain, dripping water, humidity, high temperatures (above 50°C) or dust.

Product guarantees will be made invalid if this system is used incorrectly and not in accordance with the directions explained in the product documentation, including if the product has in any way been opened and/or manipulated.

1. INTRODUCTION

1.1 Brief description

The ESDB Energy Saving Device allows efficient energy control and management in residential and hospitality environments. The system will manage the room power according to the room presence status.

External detectors (Motion Detector, Door/Window Detector) are needed to complete the system.

1.2 Material included

The basic system is comprised of the following equipment:

- 1 Energy Saver
- 1 Motion Detector
- 1 Door/Window Detector
- 1 Cards kit
- User manual

2. INSTALLATION

2.1 Installation safety information

Please read the instructions included here before starting, and follow them carefully prior to installation and using the Energy Saver.

1. Use the device only with the power supply indicated on the product documentation. If you are unsure about the type of power supply used on your installation, please contact your electric company.
2. Be sure to turn off the power before performing any maintenance or modifications to the installation.
3. Any incorrect connections can result in personal injury an/or can cause irreparable damage to the product.
4. The device's electrical connections must follow official standards and valid legal directives and requirements.
5. The installation must include a device that cuts the power to the Energy Saver in the case of any possible spike to the device due to a malfunction.



2.2 Technical characteristics

RF model reference	ESDB
Description:	Wireless Non-card Energy Saver
Power supply:	110 - 230 Vca.
Consumption:	Nominal 30 mA, Maximum 50 mA (230 Vac)
Frequency	50 – 60 Hz.
Output relay:	2 Relays (free potential with 2 contacts NO / NC) Cutting power: 12 A, 230 V~,cos ϕ =1 8 A, 230 V~,cos ϕ = 0,6 Incandescent max. load: 10 A. Halogen max. load: 10 A. Cutting power max. in NC contact: 12 A, 230 V~,cos ϕ =1 8 A, 230 V~,cos ϕ = 0,4 Incandescent max. load.10 A. max. Halogen 10 A.
Dimensions:	90,2x53,30x57,50mm
Weight:	183g
Housing	PC/ABS fireproof (according to norm UL94V-0)
Pilots:	Tricolour LED (amber, red, green)
Temperature range:	0° - 50°

2.3 Installation process

Ensure that the cables used in the electrical installation of the device are no connected to the electrical supply during the installation process.

2.3.1 Mechanical assembly

This unit is designed to be mounted on a DIN rail.

2.3.2 Connection diagram

The device electrical connections must follow the local standards and the official regulations.

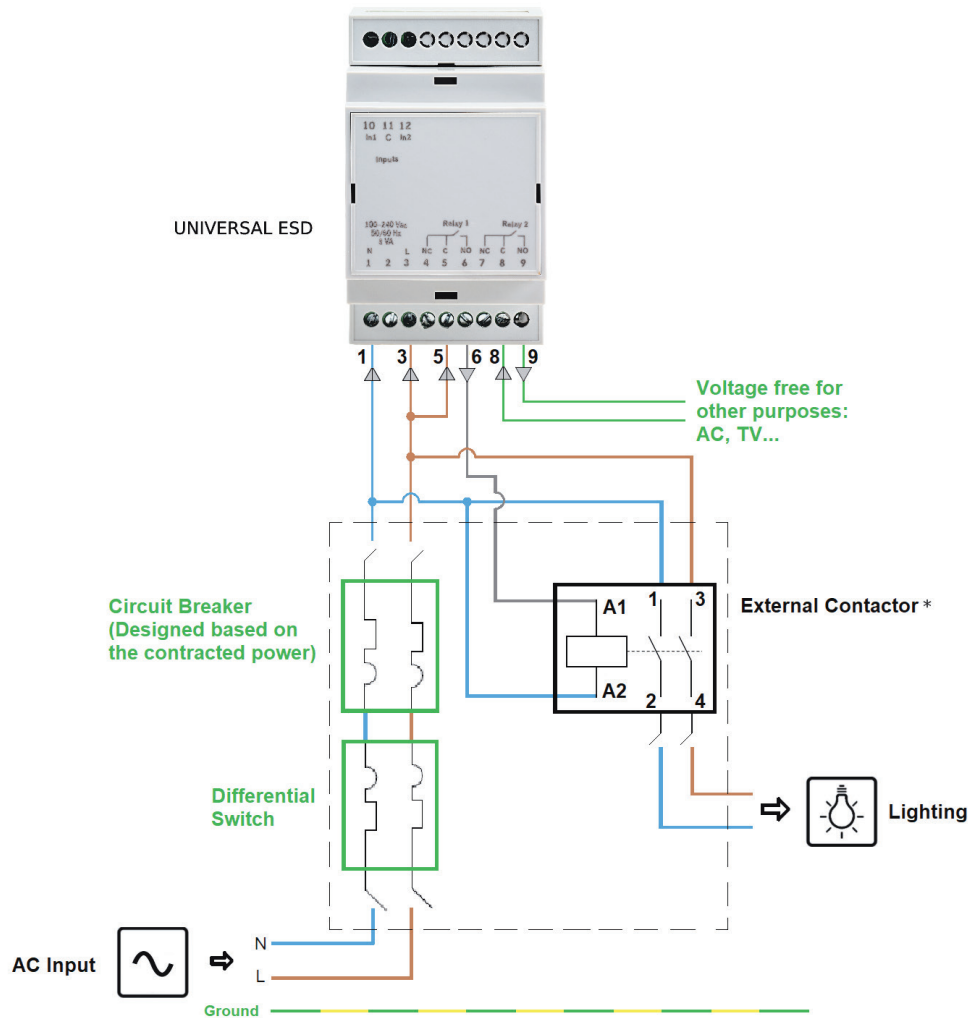

* An external contactor may be needed if the connected load exceeds the maximum ESD power requirements.

Connection Diagram 1



2.3.3 Confirming correct installation

With the mechanical and electrical assembly completed, you can now test the device to ensure that it is ready and can be put into use.

1. Check that the Energy Saver is connected according to the connection diagram 1
2. Ensure that the unit is plugged into a connected electrical line.
3. Confirm that the LED shows a continuous amber light.

3. OPERATION

The Energy Saver must be plugged into the electrical grid as explained in Electrical Characteristics (2.2). Each Energy Saver device has two output relays wherein one is used to activate electrical current (such as lighting) and the other is used for other applications (such as air conditioning).

Considerations:

The room is considered as empty.

The main door is equipped with a door detector.

The room is equipped with a motion detector.

- The main door is open and the relay 1 is activated. The guest can now control the lighting.
- Relay 2 is activated as soon as the motion detector detects the guest.
- The room is occupied.
- If no door is detected (open/close - a person entering/leaving the room), both relays will be maintained activated.
- If someone leaves the room, the Door Detector will register the door closing and will communicate this to the Energy Saver. The Motion Detector will start searching for motion as per the configuration set-up (15 or 60 minutes for relay 1 and 15 minutes for relay 2).
- If no motion is detected during the setup time period, the Energy Saver will turn the lighting (Relay 1) and the air conditioning (Relay 2) off until motion is again detected in the room. The Relay 2 timing is always fixed at 15 minutes.
- If a Window Detector registers that a window has been opened for more than 30 seconds, it will communicate this to the Energy Saver and Relay 2 will be turned off, thus deactivating the air conditioning or heating systems. This will also result if the main door is left open for more than 30 seconds.

3.1 Synchronizing the Energy Saver with Motion and Door/Window Detectors

To synchronize an Energy Saver to its Detectors, follow these steps:

1. Present the **Sensor Synchronizing Card** to the **Energy Saver**, putting the device into Synchronizing Mode.

2. With the Energy Saver in Synchronizing Mode, press the Detector's inner button (see Detector section).
3. The Detector's LED will now go red, and the Detector and Energy Saver will now begin to synchronize. When the synchronization process has been successfully completed, the Detector will blink red for a couple of seconds, followed by four slow blinks and the LED will go off.
4. Repeat these steps for all the Detectors that need to be synchronized to the same Energy Saver.
5. Once all the Detectors are synchronized, remove the Synchronizing Card from the Energy Saver to exit Synchronizing Mode.

Please note that this same Synchronization Card can be used for the synchronization of each room's devices.

IMPORTANT! Synchronize each detector one at a time. Do not synchronize several energy savers at the same time.

3.2 Special card kits

The following cards are included in the kit:

- **Synchronizing Card.** It is used to put an Energy Saver in Synchronizing Mode (LED blinks amber) and synchronize with the Detectors in the same room.
- **Sensor Deleting Card.** It is used to desynchronize a room's Energy Saver from the Detectors in the same room. (LED blinks green to indicate the number of Detectors desynchronized from the Energy Saver.) The Energy Saver is now ready to be synchronized with new Detectors.
- **Motion Detector Time Card (15 min).** It is used to change the lightning (relay 1) motion detection time to 15 minutes. Once a door is closed, the Motion Detector search for motion in the room for the next 15 minutes before shutting off.
- **Motion Detector Time Card (60 min).** It is used to change the lightning (relay 1) motion detection time to 60 minutes. Once a door is closed, the Motion Detector search for motion in the room for the next 60 minutes before shutting off electricity.

4. CLEANING AND MAINTENANCE

Although the Energy Saver does not require regular maintenance, it should be gently cleaned occasionally with a damp cloth. Do not use a stream of water or steam.

5. RESPECTING THE ENVIRONMENT



This device is made of recyclable materials. Please follow your local ordinances regarding the correct disposal of waste. Recycling helps reduce the consumption of raw materials and of environmental contamination.

\\USER MANUAL

SALTO ESDB | Universal Energy Saver

The ESDB “cardless” energy saver is an electronic device that allows energy control and management in residential and hospitality environments.

The system permits energy to be connected once a person’s presence is detected in the controlled area or room.

Universal Energy Saver ESDBRD - Flush Mounted Motion Detector

SALTO
inspiredaccess

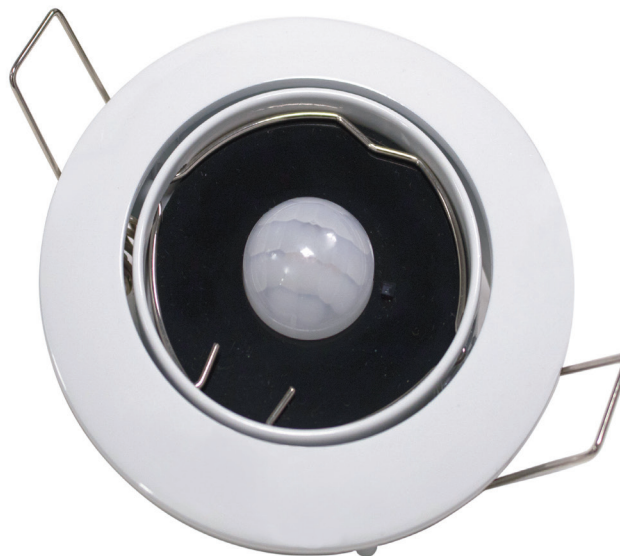



Read the following instructions carefully before installing the product and keep this document for future reference.

General warnings and instructions to ensure the correct operation of the product in your installation:

1. The installation and use of the product must be done in accordance with the instructions included in this document.
2. Correct operation of the unit is the client's responsibility. SALTO is not responsible for any damages resultign from the incorrect use of the product.
3. If a unit has failed to function correctly and/or has been damaged, please contact your SALTO dealer and do not try to repair and reinstall the unit yourself.
4. This device should be used only in indoor environments.

1. INTRODUCTION

1.1 Brief description

The adjustable flush mounted volumetric sensor is a passive infra-red device that detects motion inside the room.

The unit is self-contained and is powered by a 3V CR123A lithium battery (not rechargeable).



1.2 Material included

- Flush mounted volumetric sensor.
- Instructions and start-up manual



2. INSTALLATION

The flush mounted volumetric detector is always installed on the ceiling of the room*. The device is installed by hooking to the ceiling with the tabs. It is necessary to bore a 75mm hole in the ceiling in order to insert the detector.

The detector's installation position must be taken into account. Detection coverage is shown below to help positioning. It may be necessary to install more than one detector per room.

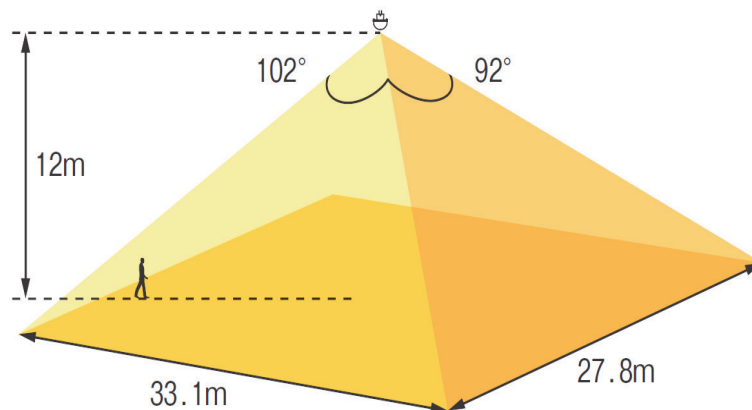

It detects motion as soon as any movement above a speed of 1 m/s is detected in the detection zone..

* **Basic Principles**

PaPIRs is a pyroelectric infrared sensor that detects variations in infrared rays. However, it may not detect in the following cases: lack of movement, no temperature change in the heat source. Besides, it could also detect the presence of heat sources other than a human body. Efficiency and reliability of the system may vary depending on actual operating conditions:

1) Detecting heat sources other than the human body, such as:

- a) Small animals entering the detection area
- b) When a heat source for example sun light, incandescent lamp, car headlights etc, or strong light beam hit the sensor regardless inside or outside the detection area.
- c) Sudden temperature change inside or around the detection area caused by hot or cold wind from HVAC, or vapor from the humidifier, etc.

2) Difficulty in sensing the heat source

- a) Glass, acrylic or similar materials standing between the target and the sensor may not allow a correct transmission of infrared rays.
- b) Non-movement or quick movements of the heat source inside the detection area.

3) Expansion of the detection area

In case of considerable difference in the ambient temperature and the human body temperature, detection area may be wider apart from the configured detection area.

2.1 Dimensions

The diameter and height dimensions of the flush mounted volumetric sensor are shown in the following images.



2.2 Installation process

The flush mounted volumetric sensor should be installed in the following order:

1. Mark the position of the hole to be drilled.
2. Drill a hole with a 75mm crown.
3. Synchronise the sensor and the Energy Saver.

Present the Sensor Synchronising Card on the energy saver which will then remain in synchronisation mode until the card is removed again. Press the Sensor's internal pushbutton with your hand while the Sensor Synchronising Card is on the energy saver. The red pilot light will come on.



The sensor and the energy saver will then try to synchronise. Synchronisation is correct when the red sensor flashes very quickly for about five seconds. The red pilot light must go off then. Repeat the same procedure with all the sensors in the same room that must be synchronised with the same energy saver. Remove the card from the energy saver once all sensors have been synchronised.

4. Position the flush mounted volumetric sensor in the ceiling and secure it using the two tabs.

2.3 Desynchronization of detectors

Sensors are desynchronised when the sensor delete card is presented to the energy saver. The energy saver deletes the list of all synchronised sensors.

Desynchronisation is necessary in the following cases:

- When one of the sensors has to be removed from the room.
- When a sensor fails and needs to be replaced.

The room sensors must always be resynchronised with the energy saver after desynchronising.



Desynchronisation is NOT necessary in the following cases:

- When changing the sensor batteries.
- When adding a new sensor to the room.

3. MAINTENANCE AND CLEANING

To keep your device functioning properly, ensure that the optic is clean and nothing is glued or fixed to it.

Batteries should be replaced approximately every 2 years or sooner if the detector light starts blinking red.

3.1 Battery replacement

When the battery needs to be changed, the Motion Detector LED will flash red three times every eight seconds.

4. RESPECTING THE ENVIRONMENT

Dispose of used batteries correctly, in an authorized collection point, and never in the general trash.

5. TECHNICAL DATA



ESDBRD-WIRELESS ADJUSTABLE RECESSED VOLUMETRIC SENSOR FOR ENERGY SAVER	
REFERENCE	SVExlxS
POWER	1 CR123A 3 V battery
BATTERY LIFE	5 years (Mean consumption 18uA, Maximum 20mA)
COMMUNICATIONS	Wireless 2.4 GHz, IEEE 802.15.4
COMMUNICATIONS COVERAGE	10m (Maximum distance to the energy saver)
INTERFACE	Red LED
TEMPERATURE/HUMIDITY RANGE	Temperature: -40° to 160°
TECHNOLOGY	Passive infra-red detector.
DETECTION COVERAGE	For a height of 12 m, an area of (32x28) m
ASSEMBLY HEIGHT	Maximum height 12 m
THERMOSTAT PRECISION	Temperature: $\pm 0.5^{\circ}$ (15° to 40°), $\pm 1^{\circ}$ (0° to 60°)
DIMENSIONS	□ 85 mm x 37 mm
WEIGHT	90 g

Notes:

A large area of the page is filled with horizontal dashed lines, providing a space for handwritten notes.



\\USER MANUAL

SALTO ESDB | Universal Energy Saver

The ESDB “cardless” energy saver is an electronic device that allows energy control and management in residential and hospitality environments.

The system permits energy to be connected once a person’s presence is detected in the controlled area or room.

Universal Energy Saver ESDBMD - Surface Mounted Motion Detector

SALTO
inspiredaccess





Read the following instructions carefully before installing the product and keep this document for future reference.

General warnings and instructions to ensure the correct operation of the product in your installation:

1. The installation and use of the product must be done in accordance with the instructions included in this document.
2. Correct operation of the unit is the client's responsibility. SALTO is not responsible for any damages resultign from the incorrect use of the product.
3. If a unit has failed to function correctly and/or has been damaged, please contact your SALTO dealer and do not try to repair and reinstall the unit yourself.
4. This device should be used only in indoor environments.

1. INTRODUCTION

1.1 Brief description

This surface mounted motion detector is a passive infrared detector device that detects a person's movement inside an enclosed space or room. This device communicates wirelessly to the energy saver device. With the provided information, the energy saver will connect or disconnect the room's services such as air conditioning and lights.

The Surface Mounted Motion Detector is a stand-alone device that operates with three 1.5 V LR3 AAA non-rechargeable batteries.



1.2 Material included

- Surface Mounted Motion Detector device
- Screw pack that contains:
 - Two n° 5 screws and anchors to fix the unit to the ceiling.
 - One screw that is used to fix the battery cover to the device. There are three drilled holes for this screw to allow for flexibility when the unit is mounted on the ceiling, although only 1 screw is needed to secure this back cover.



2. INSTALLATION

The Surface Mounted Motion Detector will always be ceiling-mounted*.



The Surface Mounted Motion Detector's installation requires 2 n° 5 screws and their anchors. Drill two holes in the ceiling using a n° 5 drill bit and then fit the anchors. Finish by screwing the back cover to the ceiling.

The front part of the unit is fixed to the back cover by turning it slightly counter-clockwise and then fixing it with the screw included in any of the three holes provided, in function of the installation positioning.



Note the coverage indicated in the drawings below. It may be necessary to have more than one device installed in order to have sufficient coverage.

* **Basic Principles**

PaPIRs is a pyroelectric infrared sensor that detects variations in infrared rays. However, it may not detect in the following cases: lack of movement, no temperature change in the heat source. Besides, it could also detect the presence of heat sources other than a human body. Efficiency and reliability of the system may vary depending on actual operating conditions:

1) Detecting heat sources other than the human body, such as:

- a) Small animals entering the detection area
- b) When a heat source for example sun light, incandescent lamp, car headlights etc, or strong light beam hit the sensor regardless inside or outside the detection area.
- c) Sudden temperature change inside or around the detection area caused by hot or cold wind from HVAC, or vapor from the humidifier, etc.

2) Difficulty in sensing the heat source

- a) Glass, acrylic or similar materials standing between the target and the sensor may not allow a correct transmission of infrared rays.
- b) Non-movement or quick movements of the heat source inside the detection area.

3) Expansion of the detection area

In case of considerable difference in the ambient temperature and the human body temperature, detection area may be wider apart from the configured detection area.

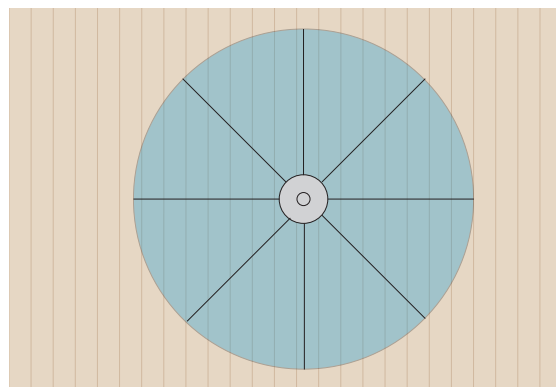
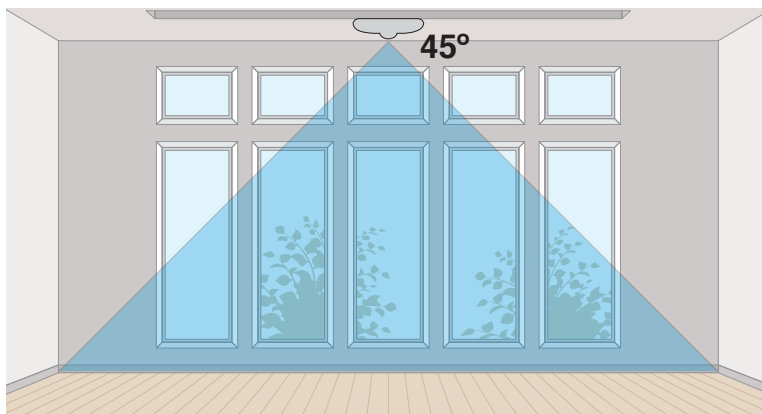

The detection area is indicated by the shaded region.

The radius of the detection area on the floor is equivalent to the distance between the floor and ceiling.

$$\text{Radius} = \text{Mounting height}$$

2.1 Dimensions

The location of and distance between the back cover mounting points are indicated in the picture below.



2.2 Installation process

Installation of the surface mounted motion detector should follow the following steps:

Synchronization of the Surface Mounted Motion Detector with Energy Saver:

1. Present the Detector Synchronization Card to the Energy Saver, and hold it on then press the CLR button inside the motion detector.

The Surface Mounted Motion Detector and the Energy Saver will now try to find each other and synchronize. The synchronization has been completed correctly when the red light flashes for approximately five seconds and then goes off.

2. Repeat this process with all the Surface Mounted Motion Detectors that will be used in the room.

Please note that the same Detector Synchronization Card can be used to synchronize other Surface Mounted Motion Detectors with other Energy Savers that will be located in other rooms.

Physical installation of Surface Mounted Motion Detector:

1. Mark two holes on the ceiling, 35 mm apart.
2. Drill the two holes using a M5 drillbit.
3. Fit the anchors in the drilled holes.
4. Separate the front cover from the back cover of the device, by turning the back cover slightly counter-clockwise.
5. Fix the back cover to the ceiling using the 2 supplied n° 5 screws.
6. Place the front cover to the back cover, and then turn the front cover clockwise slightly so that the two halves are joined. Then fix with the remaining fixing screw in one of the three holes provided

2.3 Desynchronization of detectors

To desynchronize a surface mounted motion detector from an energy saver, present the Detector Deleting Card to the energy saver. The energy saver then deletes the list of synchronized surface mounted motion detectors.

Desynchronization is necessary when:



- One of the surface mounted motion detectors will be removed and deleted.
- A surface mounted motion detector has been damaged and needs to be replaced.

Please note that after a desynchronization, it is always required to synchronize the energy saver to any surface mounted motion detectors operating in the same room.

The desynchronization is NOT necessary in the following cases:

- When the detector's batteries are changed.
- When a new detector is added to the room.

3. MAINTENANCE AND CLEANING

To keep your device functioning properly, ensure that the optic is clean and nothing is glued or fixed to it.

Batteries should be replaced approximately every 2 years or sooner if the detector light starts blinking red.

3.1 Battery replacement

When the batteries need to be changed, the Surface Mounted Motion Detector LED will flash red three times every eight seconds.

To change the batteries, follow these steps:

- Remove the screw that secures the front cover of the device to the back cover mounted on the ceiling.

- Remove the front cover from the back cover by turning it slightly counter-clockwise.
- Replace with new AAA batteries, always making sure to respect the polarity indicated. For best results, change all three batteries.

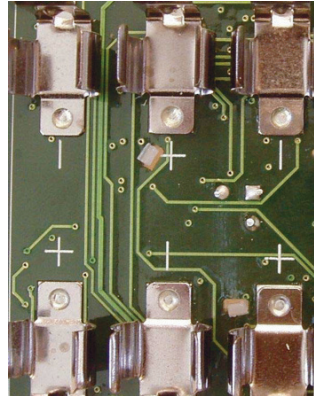

- Replace the front cover to the back cover, again sliding it slightly clockwise.
- Replace the fixing screw.



4. RESPECTING THE ENVIRONMENT

Dispose of used batteries correctly, in an authorized collection point, and never in the general trash.

5. TECHNICAL DATA

ESDBMD - MOTION DETECTOR FOR THE ENERGY SAVER	
REFERENCE	ESDBMD
POWER SUPPLY	3 batteries AAA LR3 1,5V
AUTONOMY	2 years (Average consumption 30uA, max. 20mA)
COMMUNICATIONS	Wireless 2,4 GHz , IEEE 802.15.4
COMMUNICATION COVERAGE	10m (Max. distance to the energy saver)
INTERFACE	Red LED
TEMPERATURE RANGE	-10° to 50°
TECHNOLOGY	Infrared passive detector. Fresnel lens
DETECTION COVERAGE	Ø 3m if 3m height mounted (coverage depending on the mounting height)
MOUNTING HEIGHT	Between 2,5 - 4m
THERMOSTAT ACCURACY	±2° (-10° to 50°)
DIMENSIONS	Ø 111mm x 40mm
WEIGHT	120gr.

\\USER MANUAL

SALTO ESDB | Universal Energy Saver

The ESDB Energy Saving Device allows efficient energy control and management in residential and hospitality environments.

The system permits energy to be connected once a person's presence is detected in the controlled area or room.

Universal Energy Saver ESDBBD - Door/Window Detector

SALTO
inspiredaccess



Read the following instructions carefully before installing the product and keep this document for future reference.

General warnings and instructions to ensure the correct operation of the product in your installation:



1. The installation and use of the product must be done in accordance with the instructions included in this document.
2. Correct operation of the unit is the client's responsibility. SALTO is not responsible for any damages resultign from the incorrect use of the product.
3. If a unit has failed to function correctly and/or has been damaged, please contact your SALTO dealer and do not try to repair and reinstall the unit yourself.
4. This device should be used only in indoor environments.

1. INTRODUCTION

1.1 Brief description

The Door/Window Detector consists of:

- Detector (larger box)
- Magnet (smaller box)

The correct operation of the Door/Window Detector requires that an Energy Saver is installed and synchronized with the Door/Window Detector.

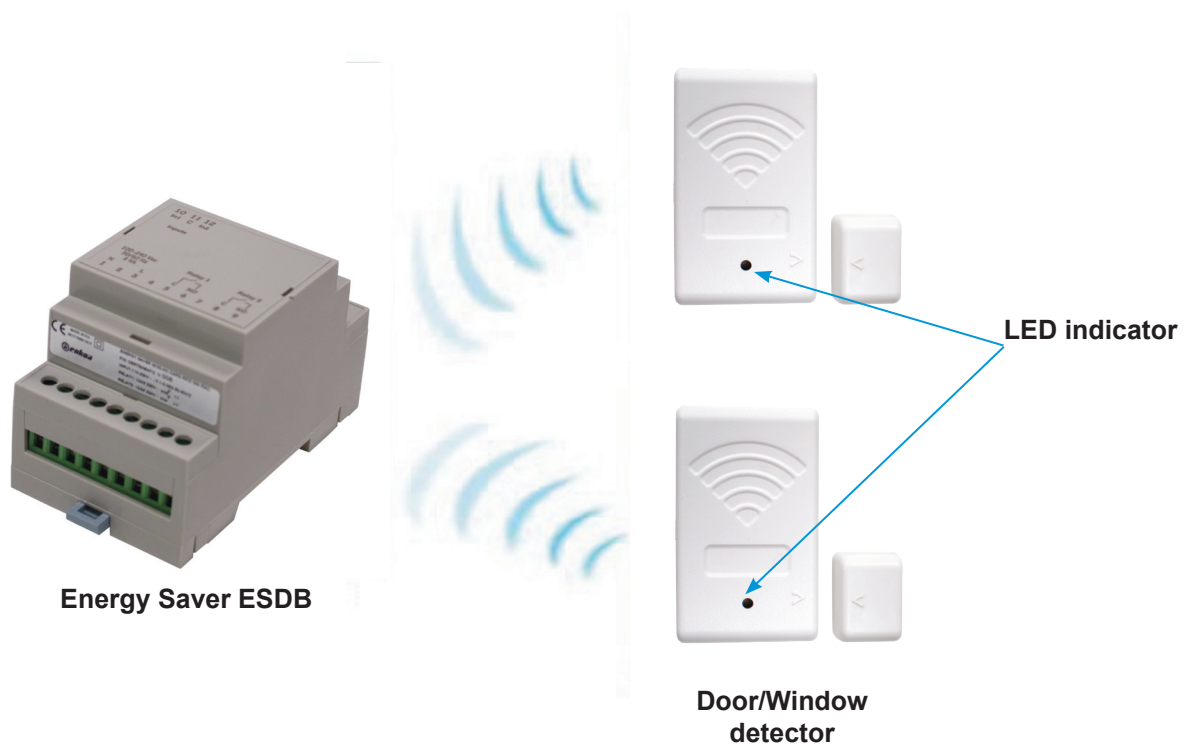

This device is designed to be installed on windows or doors such that the Detector piece sits on the window or door frame, and the Magnet sits on the door or window itself. When the Window or Door is opened, the magnet is released from the Detector and a message is sent to the Energy Saver to disconnect energy-consuming equipment like air conditioning.

The Detector uses a CR2032 watch-type battery, which under normal use last for approximately 2 years. If batteries need to be replaced earlier, the Detector indicates this by having the LED light blink red continuously



1.2 Material included

- Door/Window Detector (Detector + Magnet).
- Screw pack that includes 4 screws and 2 stickers.

2. INSTALLATION

IMPORTANT! The Door/Window Detector is designed for indoor use only!



2.1 Dimensions

The size and location of the fixing points for the Detector and the Magnet are shown in the images below.

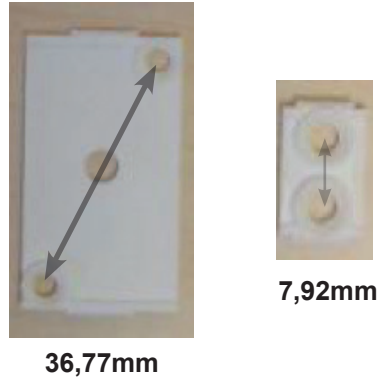

2.2 Installation process

For proper operation, the door or window should not be loose from the frame.

The Detector and Magnet should be as close together as possible, with the maximum distance permitted for correct operation set at 0.8 cm.

If the distance between the Detector and Magnet is greater than 0.8 cm, then the Door/Window Detector will most likely not work correctly.

The installation of the Door/Window Detector should follow these steps and in the indicated order.

1. Fix the Detector's base to the Door or Window frame. The stickers or the screws can be used for this.



2. Synchronize the Door/Window Detector with Energy Saver:

Present the Detector **Synchronization Card** to the Energy Saver, and hold it on then press the CLR button inside the door window detector. The Motion Detector and the Energy Saver will now try to find each other and synchronize. The synchronization has been completed correctly when the red light flashes for approximately five seconds and then goes off.

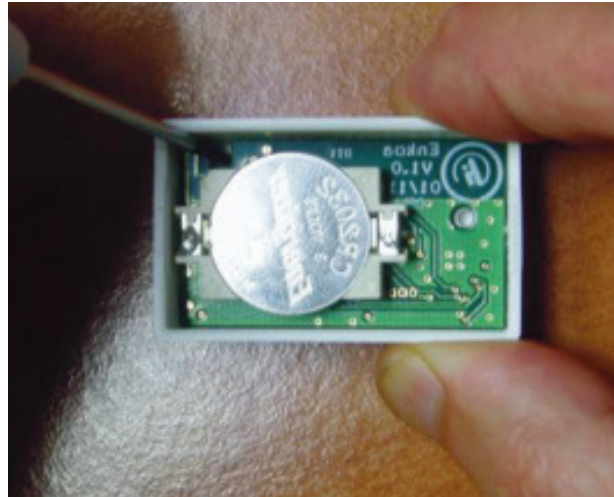

Repeat this process with all the Detectors that will be used in the room and be synchronized to the same Energy Saver.

Please note that if there is more than one Synchronization Card in the same installation, ensure that you only use one card for each room to avoid Detectors being synchronized to Energy Savers located in other rooms.

3. Fix the Magnet (using screws or stickers) at the indicated point and attached the Magnet cap to the base.

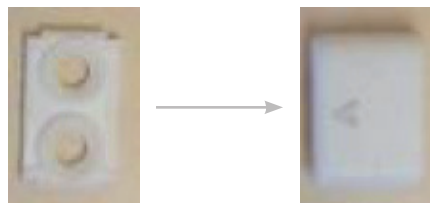

4. Once the Detector is synchronized correctly to the Energy Saver, complete the installation of the Door/Window Detector by removing the battery, waiting approximately 3 seconds, and installing the batteries once again.
5. In the next 40 seconds fix the Detector to its base in such a way that the arrows on both the Magnet and the Detector line up. It is very important that the arrows are correctly aligned for proper functioning.

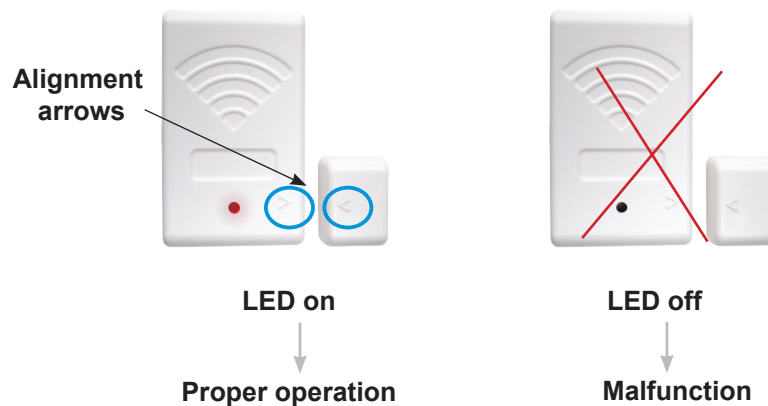

The red LED should remain on for those 40 seconds. After these 40 seconds, the LED will blink continuously showing that it is no longer in set-up mode and that it is in stand-by and ready to work.

If the LED does not follow the process explained above, the installation has not been completed correctly.

2.3 Desynchronization of detectors

To desynchronize a Detector from an Energy Saver, present the Detector Deleting Card to the Energy Saver. The Energy Saver then deletes the list of synchronized Detectors.

Desynchronization is necessary when:

- One of the room's Detectors will be removed and deleted.
- A Detector has been damaged and needs to be replaced..

Please note that after a desynchronization, it is always required to synchronize the Energy Saver to any Detectors operating in the same room.

Note that it is NOT necessary to desynchronize when a motion detector's batteries are changed or when an additional motion detector is added to the room.

3. DETECTOR CONFIGURATION

IMPORTANT! The configuration process is NOT a normal operational activity and should be done only under exceptional circumstances.

The Door/Window Detector can function as either a Door Detector or a Window Detector depending on how the Detector is configured.

By DEFAULT, the Detector is configured as a Door Detector.

3.1 Door Detector configuration

This is the default configuration of the Detector because it is the most common application. To synchronize with the Energy Saver, please follow the steps above.

3.2 Window Detector configuration

In order to configure it as window detector:

If the detector has the following built-in dip-switch please continue to b) section:

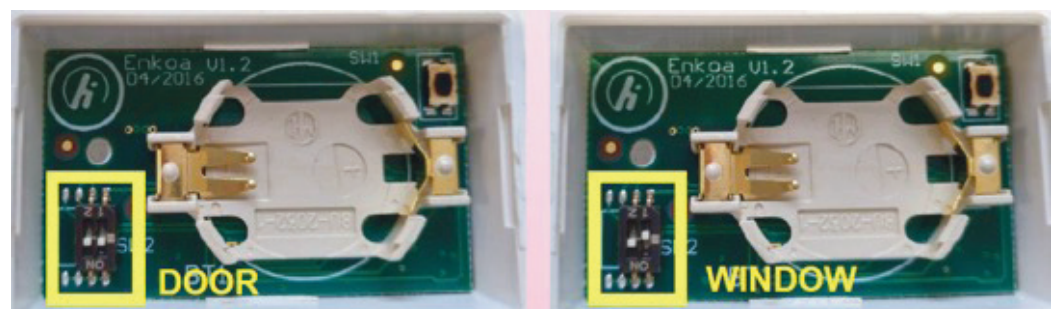

a) No dip-switch detector type

- Press the button CLR for 10 seconds which turns ON the red LED.
- After 10 seconds and releasing the button, the LED will change to a slow blinking for approximately 10 seconds and indicates that it is now configured.

To go back to Door Detector configuration, press the CLR button again for 10 seconds, which will cause the LED to change to blink rapidly for approximately 5 seconds. When the LED stops, the Detector is configured as a Door Detector again.

Determining Detector configuration

To determine the current configuration of the Detector, follow these steps:

1. Remove the battery from the Detector.
2. Wait for approximately 5 seconds, and put the battery back in the Detector.
3. With the battery re-installed, if the Detector LED turns solid ON for 6 seconds then blinks rapidly, this indicates that the Detector is configured as a Door Detector.
4. If the Detector LED blinks rapidly straightaway, then the Detector is configured as a Window Detector.

b) Built-in dip-switch detector type

Please follow the dip-switch position to switch between “door” and “window” modes (please see the picture above):

Door: 1 ON

Window: 1 OFF

4. CLEANING AND MAINTENANCE

For optimal operation of the Detector, it is recommended to change the batteries at least once every 2 years.

The Detector will indicate when the batteries need to be changed by the Door/Window Detector's LED flashing red three times every eight seconds.

4.1 Battery replacement

When batteries are about to run out the detectors warns the user, in order to be replaced. The detector blinks 3 times red every 8 seconds showing low battery.

To change the batteries, follow these steps:

- Remove the Detector's cover by popping it off with your fingers, or if this isn't possible, use a screwdriver to carefully wedge it between the Detector's base and cap.



- Replace the CR2032 battery with a new one, preferably from the same manufacturer. Take care to respect the indicated correct polarity.

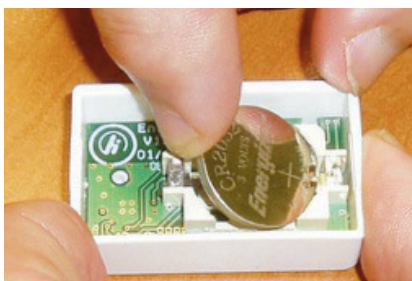

- Replace the Detector's cap to the base.

5. RESPECTING THE ENVIRONMENT

Dispose of used batteries correctly, in an authorized collection point, and never in the general trash.



6. TECHNICAL DATA

ESDBBD - DOOR / WINDOW DETECTOR FOR THE ENERGY SAVER	
REFERENCE	ESDBBD
POWER SUPPLY	3V CR2032 lithium battery
AUTONOMY	2 years (7,5µa average consumption, 20mA at most)
COMMUNICATIONS	2,45 GHz wireless , IEEE 802.15.4
COMMUNICATION COVERAGE	30m (max. distance to the energy saver)
INTERFACE	Red led
MATERIAL	"Fireproof material according to norm UL 94 V-0"
TEMPERATURE RANGE	-10° to 50°
TECHNOLOGY	Magneto resistive detector + magnet
MAX. DISTANCE BETWEEN THE Detector - MAGNET	Recommendable to have a slight separation. Max separation 0,8 cm.
DIMENSIONS (DETECTOR ,MAGNET)	Detector (44,21mmx27mm) Magnet (18,30mmx13,34mm)
WEIGHT	14g

