

- Eng Installation guide
- D Montageanleitung
- F Guide d'installation
- E Guía de instalación
- NL Installatiehandleiding
- I Guida all'installazione

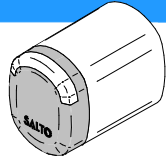

NxEx 1xx...Gx...series
 NxEx 1xx...Zx...
 NxHx 1xx...Gx...series
 NxHx 1xx...Zx...

E1/E2/E3
 H1/H2/H3

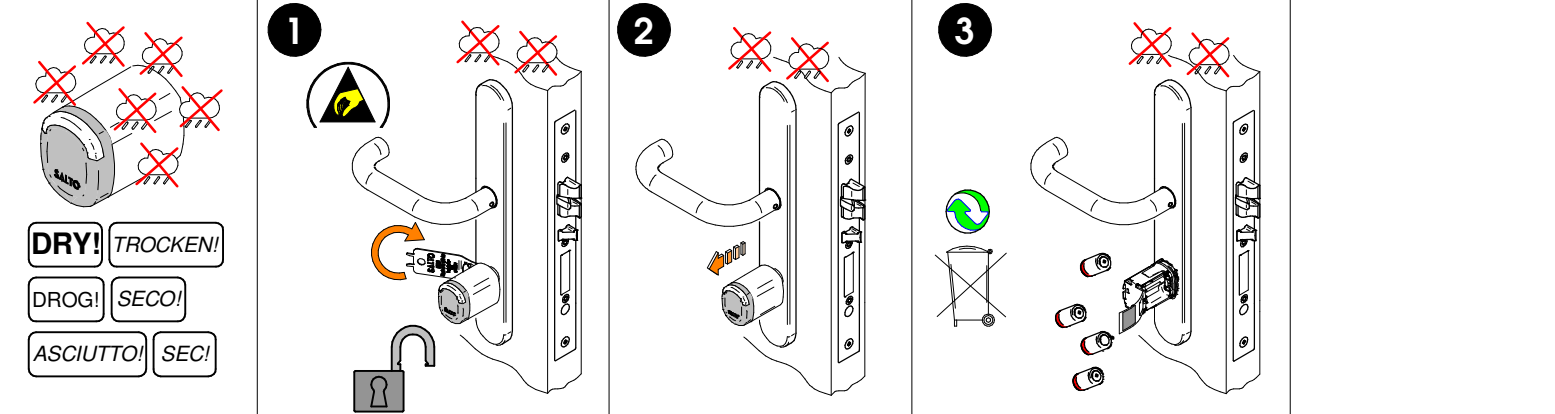
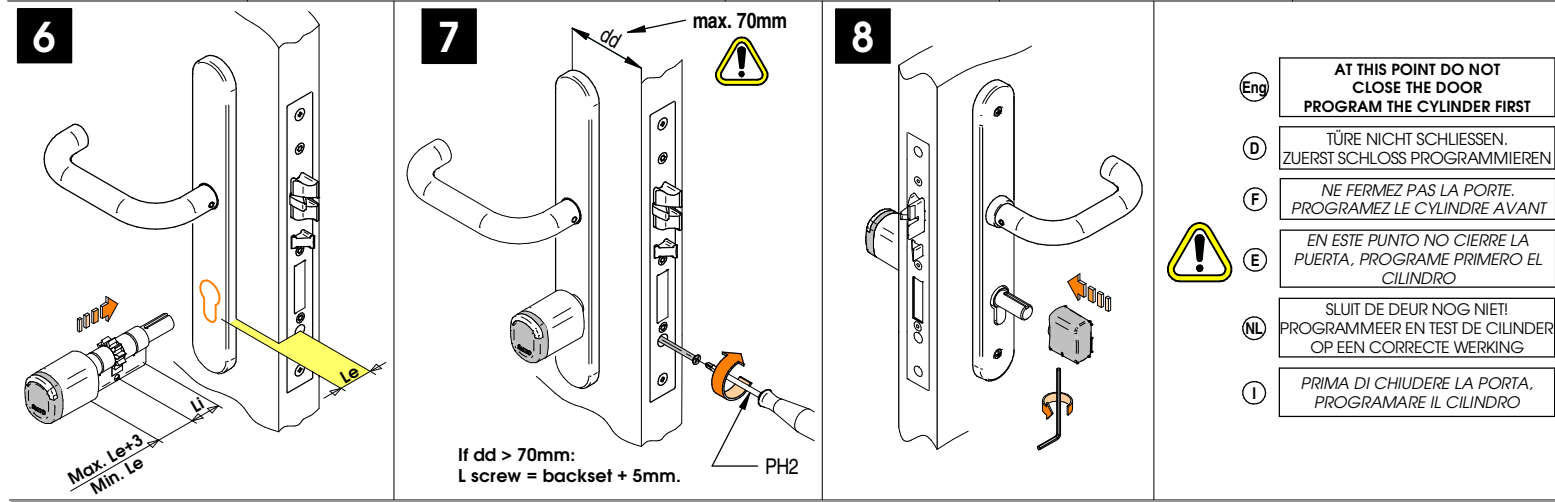
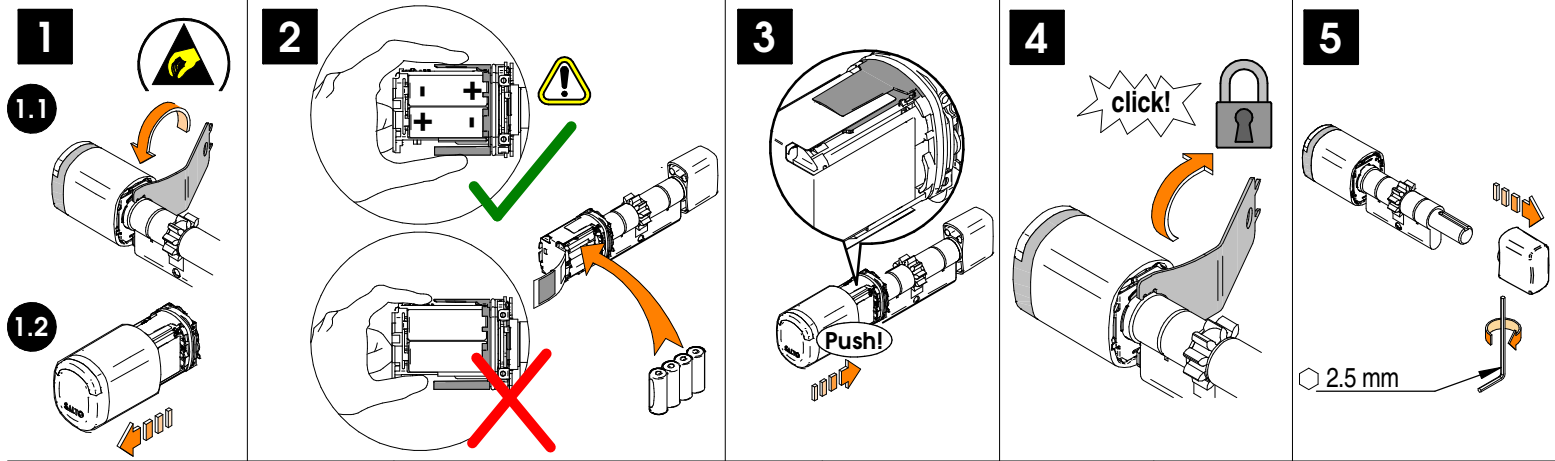
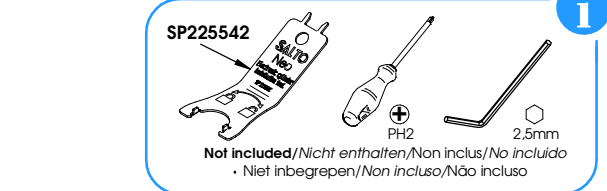
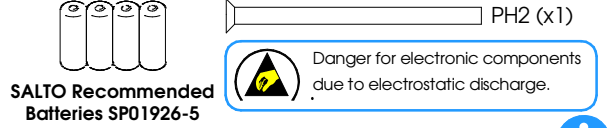
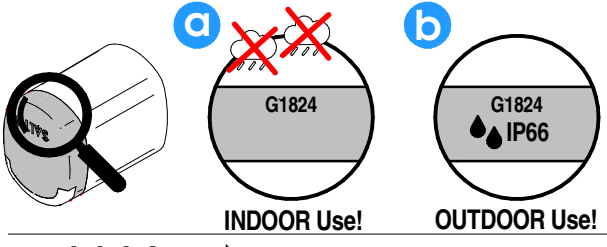
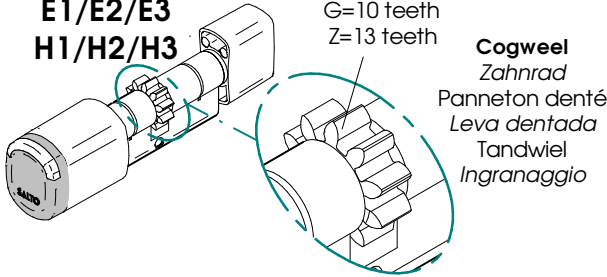

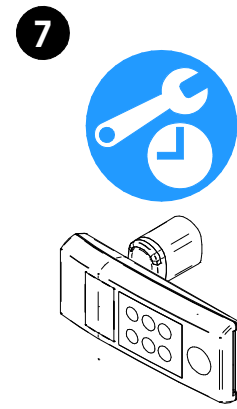
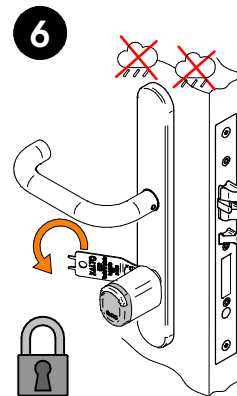
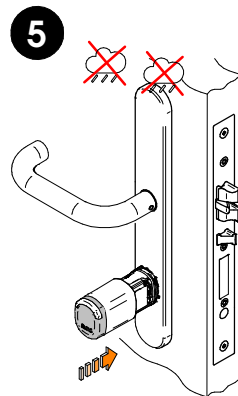
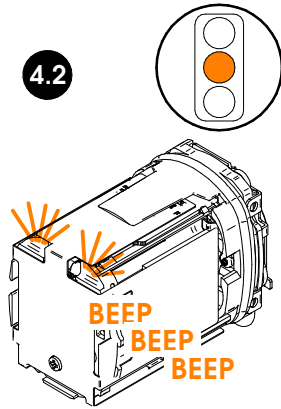
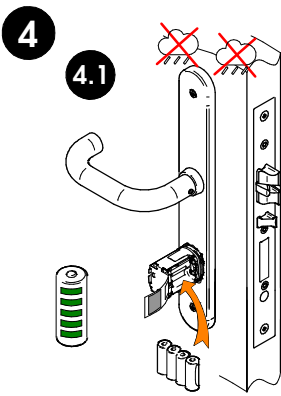

(Eng) Installation and use recommendations (D) Empfohlene Handhabung und installation (F) Recommendations d'utilisation et d'installation (E) Consejos de uso e instalación
 (NL) Installatie - en gerbuiksinstructies (I) Raccomandazioni d'uso ed d'utilizzo (P) Instruções de uso e instalação

- (Eng) Outer knob
- (D) Außenknopf
- (F) Bouton extérieure
- (E) Pomo exterior
- (NL) Buitenknop
- (I) Manopola esterna
- (P) Botão exterior

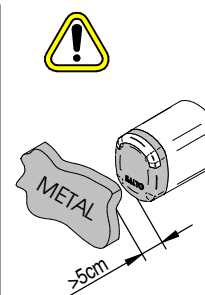
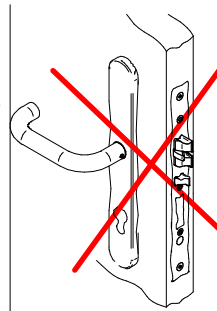
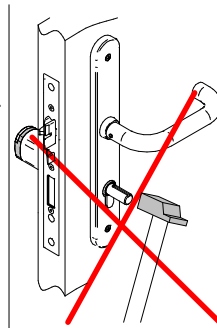
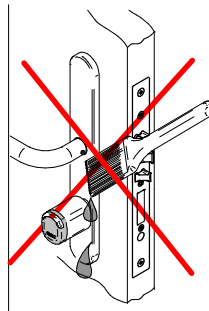
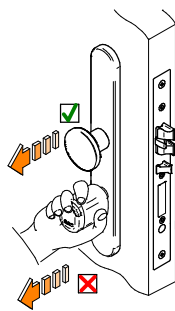
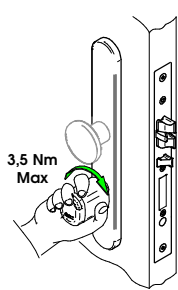
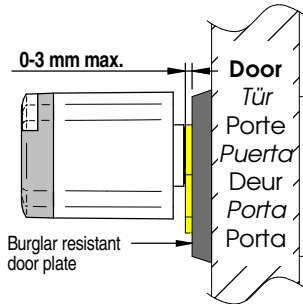

- (Eng) Do not place any movable metallic object closer than 5cm in front of the reader.
- (D) Platzieren Sie keine beweglichen Metallteile näher als 5 cm vor dem Leser.
- (F) Ne placez aucun objet métallique mobile à moins de 5 cm du lecteur.
- (E) No colocar ningún objeto móvil metálico delante del lector a menos de 5cm de distancia.
- (NL) Plaats geen enkel beweegbaar metalen voorwerp dichterbij dan 5 cm voor de lezer.
- (I) Non posizionare oggetti metallici mobili più vicini di 5 cm al lettore.
- (P) Não coloque nenhum objeto metálico mais próximo do que 5cm na frente do leitor



- (Eng) The knob is uniquely paired to the cylinder, and will not work if you switch in a different SALTO cylinder.
- (D) Der Knopf ist eindeutig mit dem Zylinder gekoppelt und funktioniert nicht, wenn Sie einen anderen SALTO-Zylinder verwenden.
- (F) Le bouton du lecteur SALTO est appairé au cylindre. Le cylindre ne fonctionnera pas si vous l'inversez avec un autre cylindre SALTO.
- (E) El pomo está emparejado únicamente al cilindro, no funcionará si lo conecta a otro cilindro SALTO diferente.

- (NL) De knop is is uniek gekoppeld aan de cilinder en zal niet werken als u de knop op een andere SALTO cilinder plaatst.
- (I) Il pomolo è accoppiato univocamente con il corpo del cilindro, non funzionerà il dispositivo se si cambia con un altro cilindro.
- (P) O botão está emparelhado ao cilindro correspondente e não funcionará se trocar por um cilindro SALTO diferente.