

Montageanleitung  
Guía de instalación  
Installatie handleiding  
Guide d'installation  
Guida all'installazione

E1 CD0 x 00 ff t models  
E1 CD2 x dd ff t  
E1 CD4 x dd ff t  
E2 CD0 x 00 ff t  
E2 CD2 x dd ff t  
E2 CD4 x dd ff t

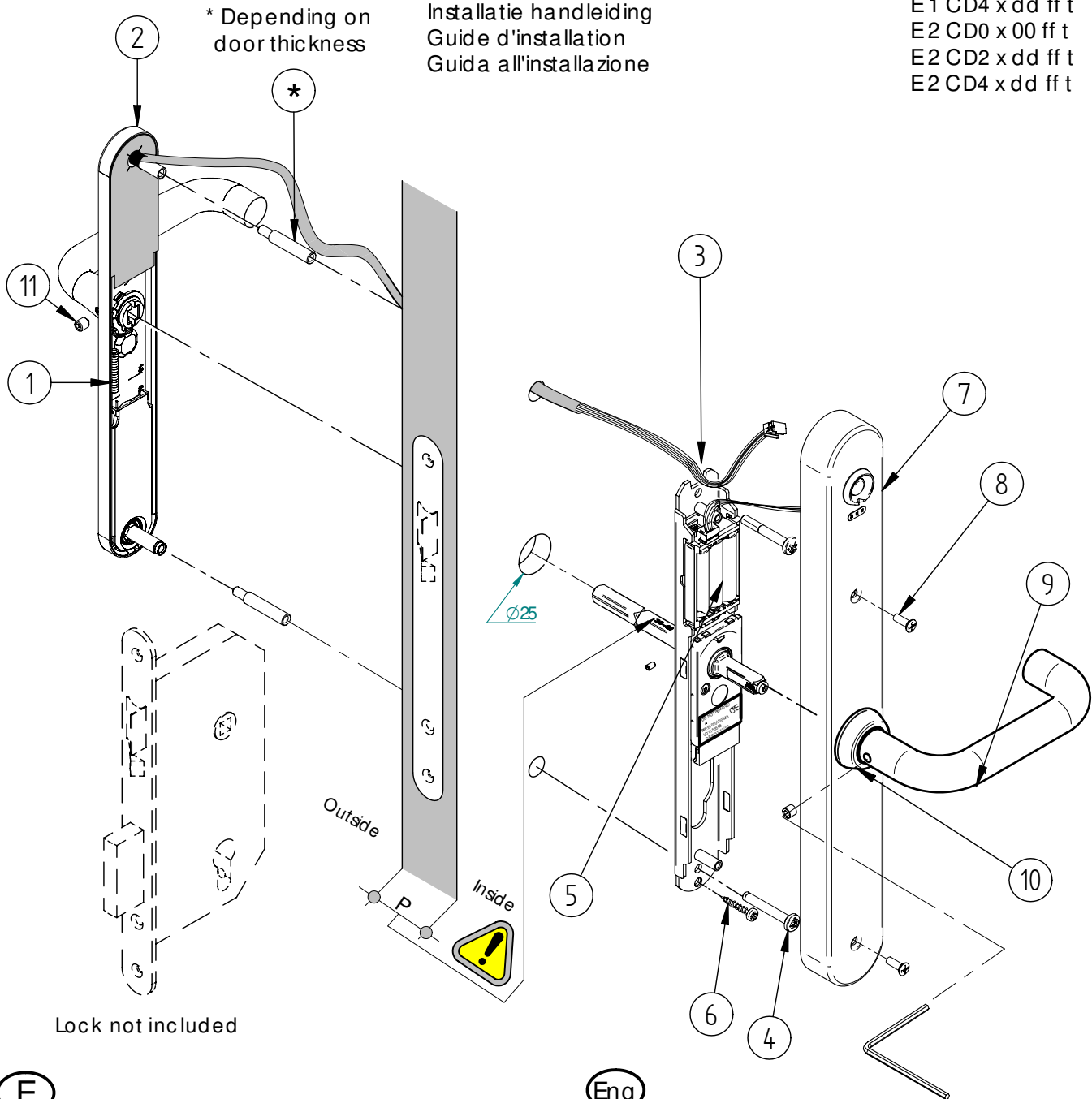

Lock not included

**(E)**

**Declaración de conformidad**

Por medio de la presente Salto Systems S.L. (Pol. Lanbarren C/Arkotz, 9 - 20180 Oiartzun - Spain - CIF B20708517), declara que este equipo cumple con los requisitos esenciales y cualesquiera otras disposiciones aplicables o exigibles de la Directiva 1999/5/CE o la Directiva 89/336/EEC. Podrá encontrar una copia de la declaración de conformidad original en la siguiente dirección de Internet: <http://www.saltosystems.com>

Todos los modelos de proximidad son "Receiver class 3".

**(F)**

**Déclaration de conformité**

Par le biais de celle-ci, Salto Systems S.L. (Pol. Lanbarren C/Arkotz, 9 - 20180 Oiartzun - Spain - CIF B20708517), déclare être conforme aux normes essentielles et n'importe quelles autres dispositions applicable et exigibles des Directives 1999/5/CE ou 89/336/EEC. Vous pourrez trouver une copie de la déclaration de conformité originale sur le site internet suivant: <http://www.saltosystems.com>

Tous les modèles de proximité sont "Receiver class 3".

**(Eng)**

**Declaration of conformity**

By means of the present Salto Systems S.L. (Pol. Lanbarren C/Arkotz, 9 - 20180 Oiartzun - Spain - CIF B20708517), declares that this equipment fulfills the essential requirements and any other applicable or indispensable dispositions of the Directive 1999/5/CE or the Directive 89/336/EEC. You will be able to find a copy of the original declaration of conformity at the following Internet address: <http://www.saltosystems.com>

All proximity models are "Receiver class 3".

**(D)**

**Konformitätserklärung**

Hiermit erklärt Salto Systems S.L. (Pol. Lanbarren C/Arkotz, 9 - 20180 Oiartzun - Spanien - UID-Nr. B20708517), dass sich dieses Produkt in Übereinstimmung mit den grundlegenden Anforderungen und den relevanten Vorschriften der Richtlinie 1999/5/EG bzw. 89/336/EWG befindet. Die Kopie der Konformitätserklärung im Originalwortlaut ist auf folgender Website zu finden: <http://www.saltosystems.com>

Alle Proximity-Modelle sind "Receiver class 3".

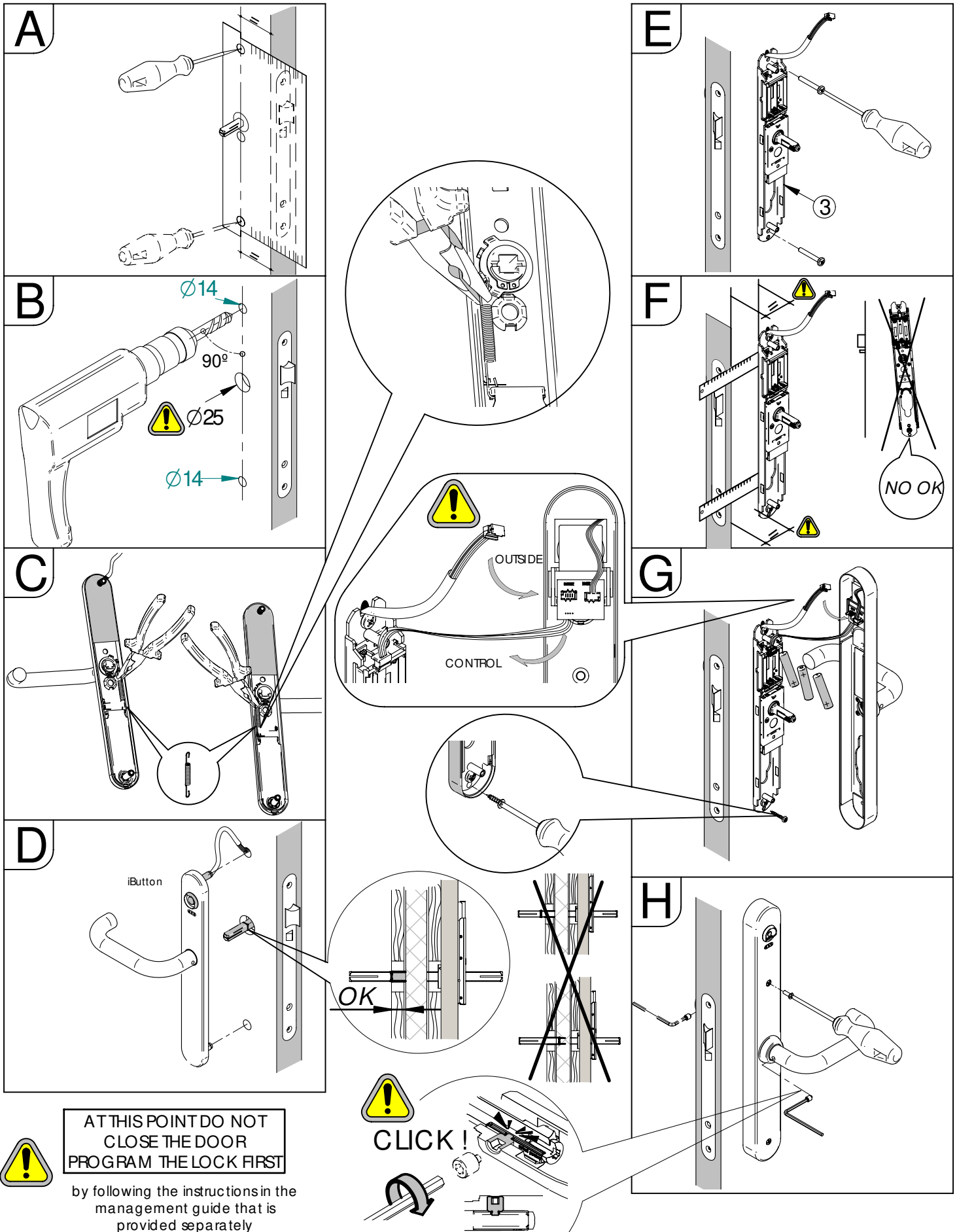

AT THIS POINT DO NOT  
CLOSE THE DOOR  
PROGRAM THE LOCK FIRST

by following the instructions in the  
management guide that is  
provided separately



CLICK!

