

# Installation guide

Ælement for EURO mortise lock (LE7Sx7x..)

# SALTO

inspired access

AE i 2 xx... series

AE i 1 xx... series

- Eng Installation guide
- D Installationsanleitung
- E Guía de instalación
- F Guide d'installation

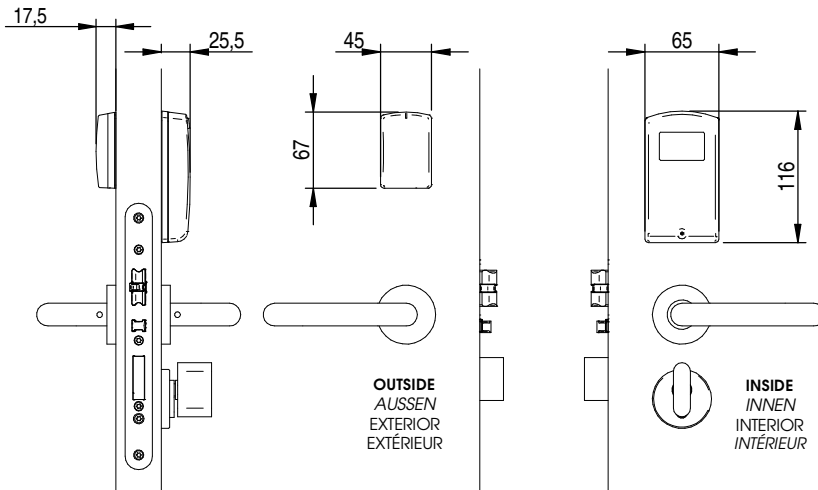

### Only SALTO spindle

Nur SALTO-Vierkant  
Solo cuadradillos SALTO  
Seulement carrés SALTO



- ⚠ Only for door thickness > 65mm.
- ⚠ Nur für Türblattstärken > 65mm.
- ⚠ Solo para grosor de puerta > 65mm.
- ⚠ Seulement pour portes de épaisseur > 65mm.

The mounting with other spindles voids the guaranty.  
Keine Garantie bei Verwendung anderer Drückervierkante.  
El montaje de otros cuadradillos anula la garantía.  
Le montage d'autres carrés annulera le garantie.

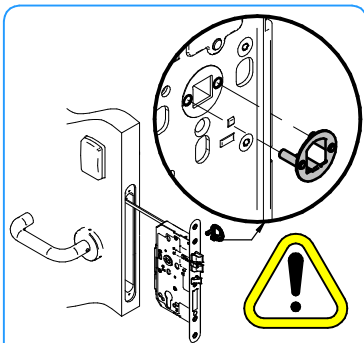

**ALWAYS IN THE OPPOSITE SIDE TO THE READER / IMMER AUF DER GEGENÜBERLIEGENDEN SELTE DES LESERS / SIEMPRE EN EL LADO CONTRARIO AL LECTOR / TOUJOURS DU CÔTÉ OPPOSE AU LECTEUR**

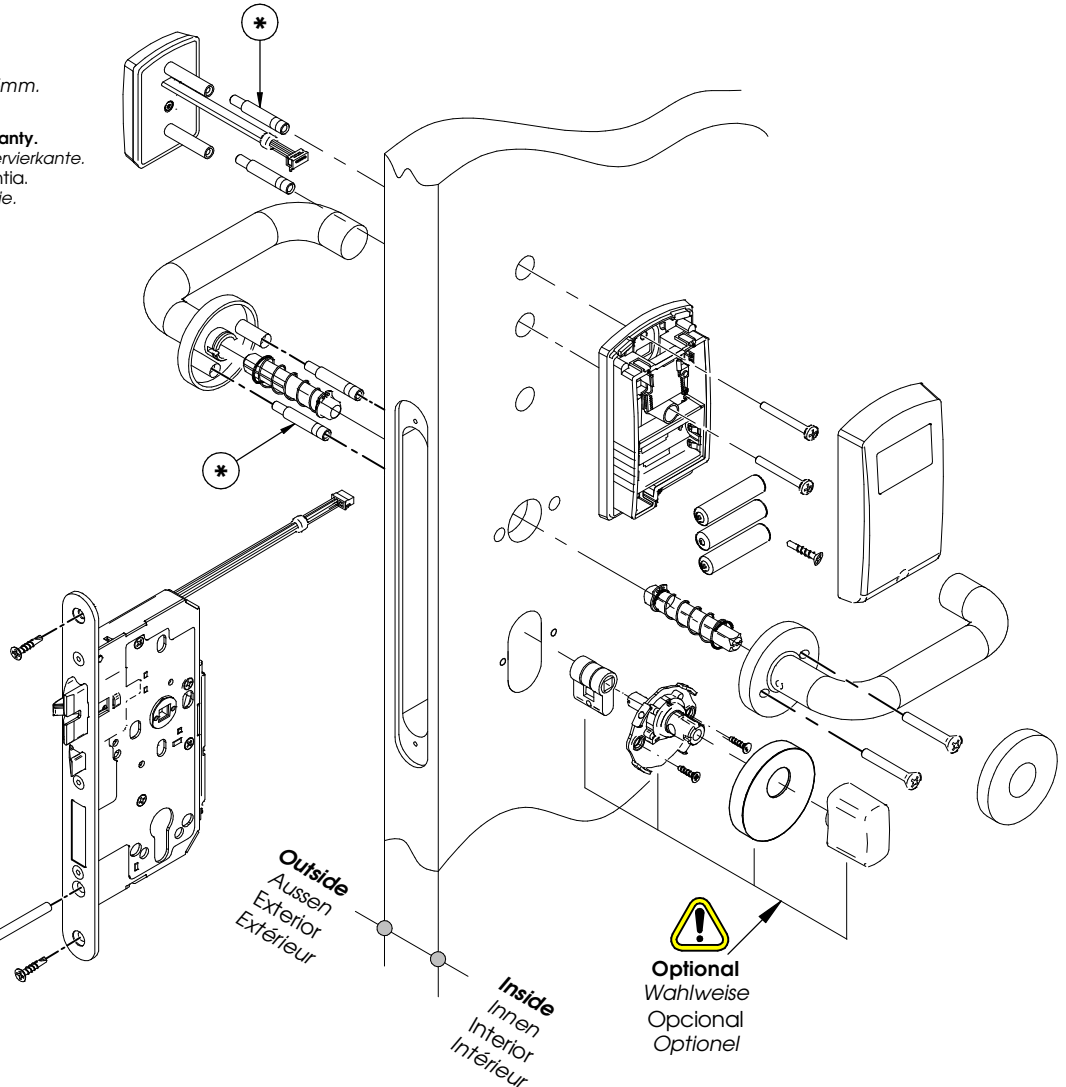

### Mortise lock not included

Einsteckschloss nicht enthalten  
Cerradura de embutir no incluida  
Serrure à mortaiser non inclusa



SALTO LE7Sx7xx

**NOTE: Screws and spindles are included in the box of the reader.**  
Anm.: Schrauben und Drückervierkant sind in Karton des Lesers enthalten  
NOTA: Los tornillos y cuadradillos están incluidos en la caja del lector.  
NOTE: Les vis et les carrés sont inclus dans la boîte du lecteur.

### Recommendation for Customer's lever set installation on SALTO Ælement.

See: 4AN01299  
Empfehlung zur Installation von kundenspezifischem Drückerset auf SALTO Ælement.  
Sehen: 4AN01299  
Recomendaciones para la instalación de manillas Cliente en SALTO Ælement.  
Ver: 4AN01299  
Recommandation pour l'installation des béquilles Client sur Salto Ælement.  
Voir: 4AN01299

# Installation guide

## Ælement for EURO mortise lock (LE7Sx7x..)

# SALTO

inspiredaccess

