

# Installation guide AELEMENT

## Euro Lock Selflocking



**SALTO**  
inspiredaccess

AE i 0 xxx... series  
(NO electronic privacy)

- Eng Installation guide
- E Guía de instalación
- F Guide d'installation
- D Installationsanleitung
- I Guida all'installazione

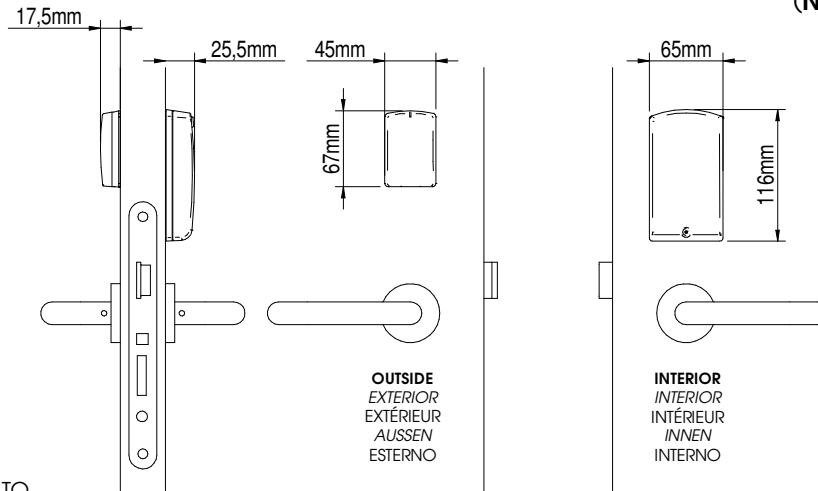

**Only SALTO spindle**  
Solo cuadradillos SALTO  
Seulement carrés SALTO  
Nur SALTO-Vierkant  
Solo quadro maniglia SALTO

\* Only for doors > 65mm (2-9/16") thickness.

\* Solo para puertas > 65mm de espesor.

\* Uniquement pour portes > 65 mm d'épaisseur.

\* Nur für Türblattstärken > 65 mm.

\* Solo per portes > 65 mm di spessore.

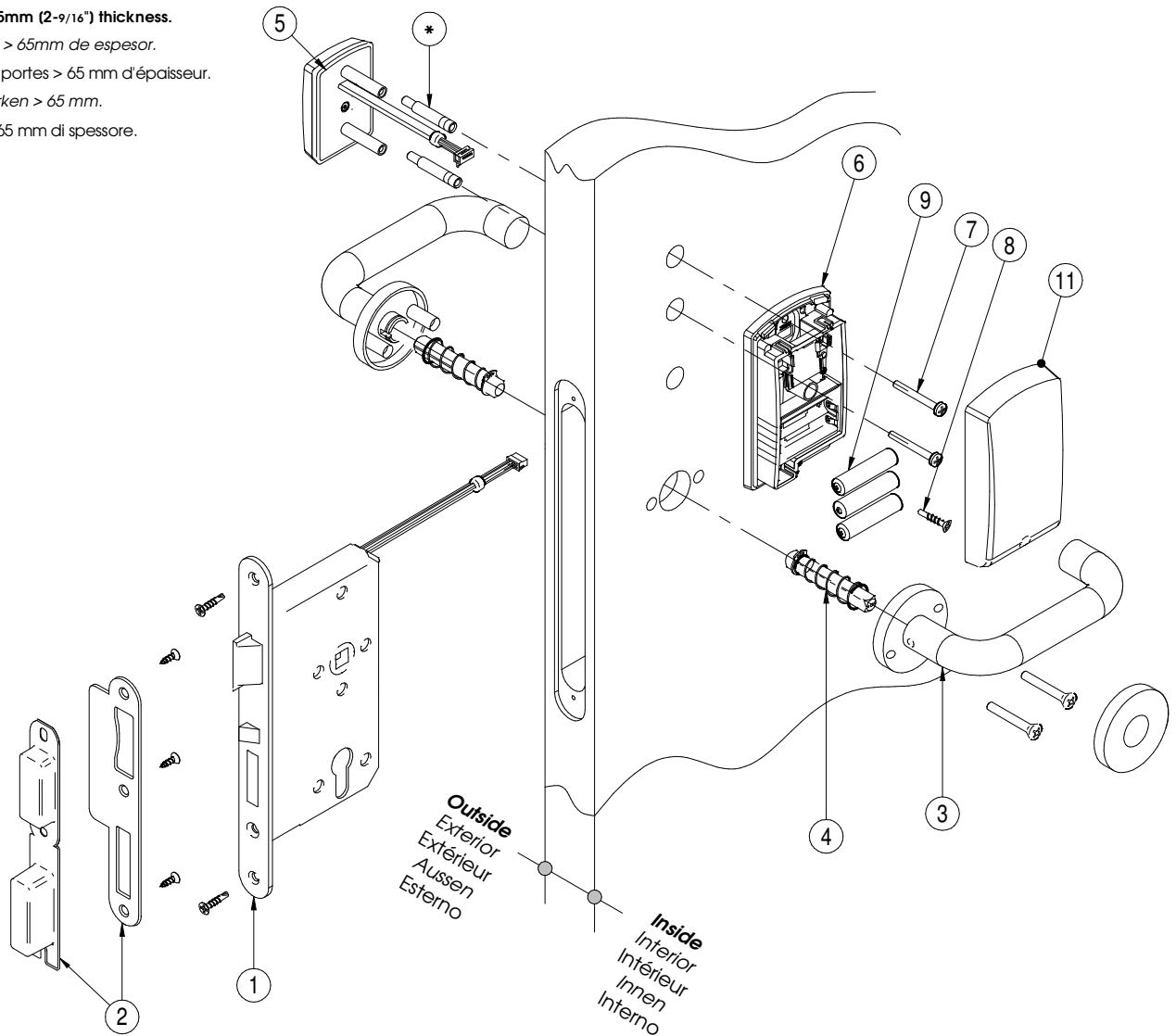

The mounting with other spindles voids the guaranty.

El montaje de otros cuadradillos anula la garantía.

Le montage d'autres carrés annulera le garantie.

Keine Garantie bei Verwendung anderer Drückervierkante.

Il montaggio con un altro quadro maniglia annulla la garanzia.

**NOTE: Screws and spindles are included in the box of the reader.**

NOTA: Los tornillos y cuadradillos están incluidos en la caja del lector.

NOTE: Les vis et les carrés sont inclus dans la boîte du lecteur.

Anm.: Schrauben und Drückervierkant sind in Karton des Lesers enthalten

NOTA: Viti e quadro maniglia sono inclusi nella confezione del lettore.

220367-ED. 14/09/2016 Installation guide AELEMENT

# Installation guide AELEMENT

## Euro Lock Selflocking



**SALTO**  
inspiredaccess

AE i 1 xxx... series  
(With electronic privacy)

- Eng Installation guide
- E Guía de instalación
- F Guide d'installation
- D Installationsanleitung
- I Guida all'installazione

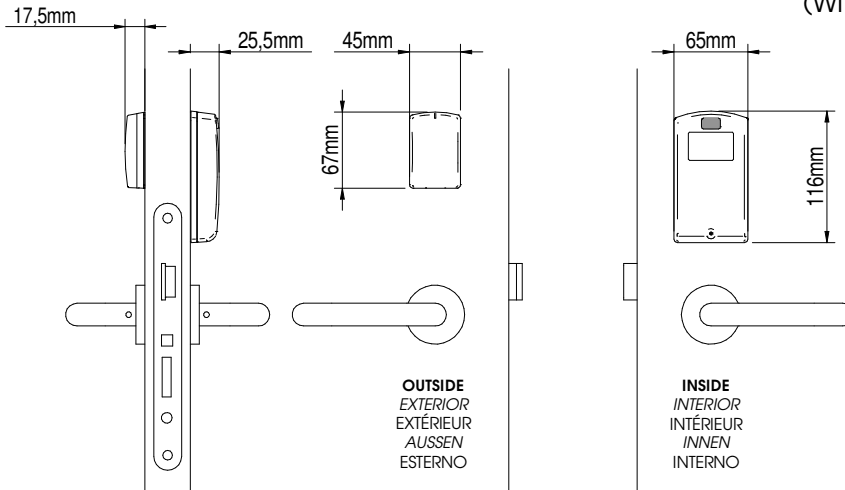

**Only SALTO spindle**  
Solo cuadradillos SALTO  
Seulement carrés SALTO  
Nur SALTO-Vierkant  
Solo quadro maniglia SALTO

- \* Only for doors > 65mm (2-9/16") thickness.
- \* Solo para puertas > 65mm de espesor.
- \* Uniquement pour portes > 65 mm d'épaisseur.
- \* Nur für Türblattstärken > 65 mm.
- \* Solo per portes > 65 mm di spessore.

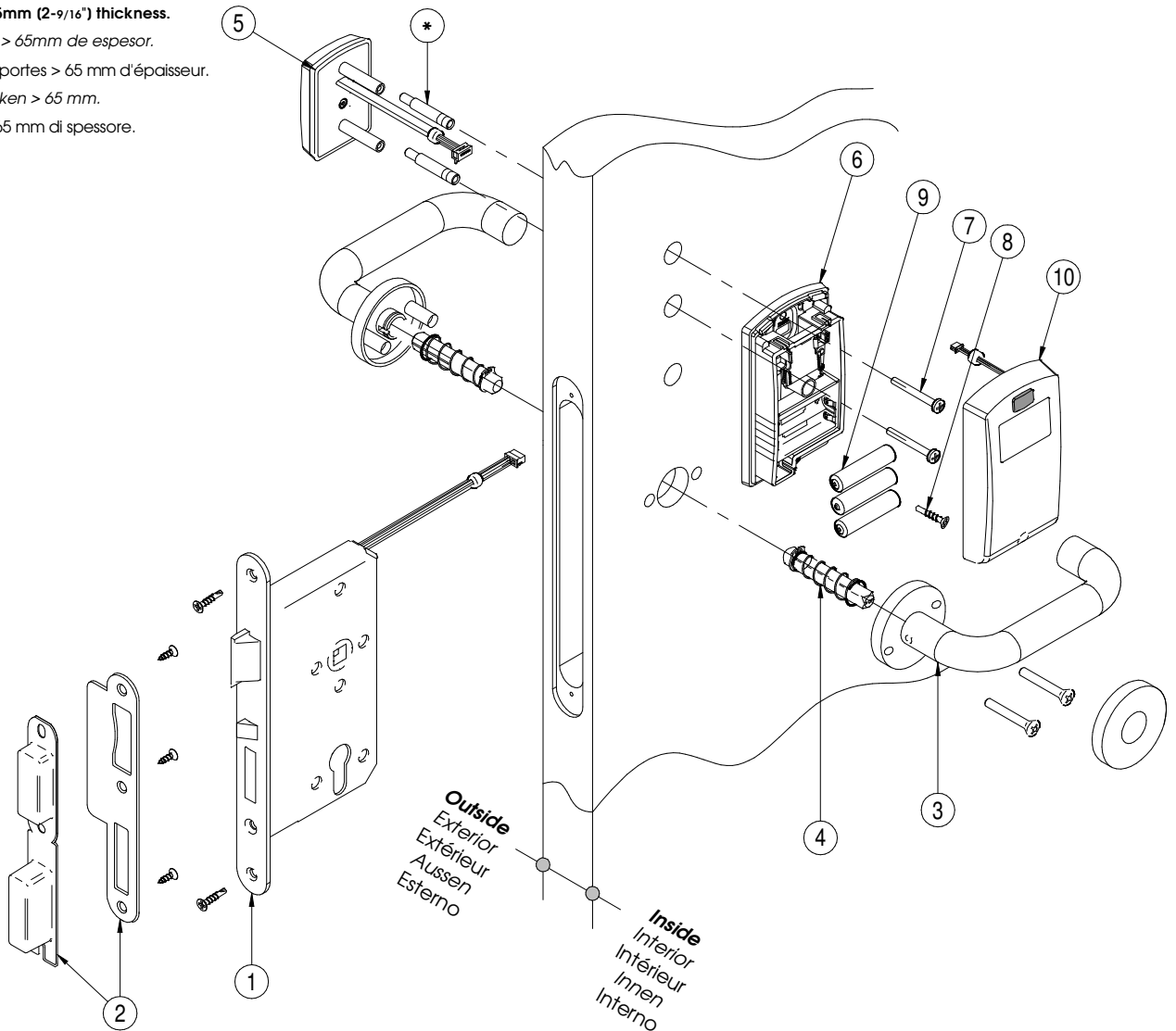

**The mounting with other spindles voids the guaranty.**  
El montaje de otros cuadradillos anula la garantía.  
Le montage d'autres carrés annulera la garantie.  
Keine Garantie bei Verwendung anderer Drückervierkante.  
Il montaggio con un altro quadro maniglia annulla la garanzia.

**NOTE: Screws and spindles are included in the box of the reader.**  
NOTA: Los tornillos y cuadradillos están incluidos en la caja del lector.  
NOTE: Les vis et les carrés sont inclus dans la boîte du lecteur.  
Anm.: Schrauben und Drückervierkant sind in Karton des Lesers enthalten  
NOTA: Viti e quadro maniglia sono inclusi nella confezione del lettore.

**Recommendation for Customer's lever set installation on SALTO AEElement.**  
See: 4MO01299  
Recomendaciones para la instalación de manillas Cliente en SALTO AEElement.  
Ver: 4MO01299  
Recommandation pour l'installation des béquilles Client sur Salto AEElement.  
Voir: 4MO01299  
Empfehlung zur Installation von kundenspezifischem Drückerset auf SALTO-AEelement.  
Sehen: 4MO01299  
Raccomandazioni per l'installazione delle maniglie fornite dal cliente nel sistema Salto AEelement.  
Vedere: 4MO01299

# Installation guide AELEMENT

## Euro Lock Selflocking



**SALTO**  
inspired access

**1**

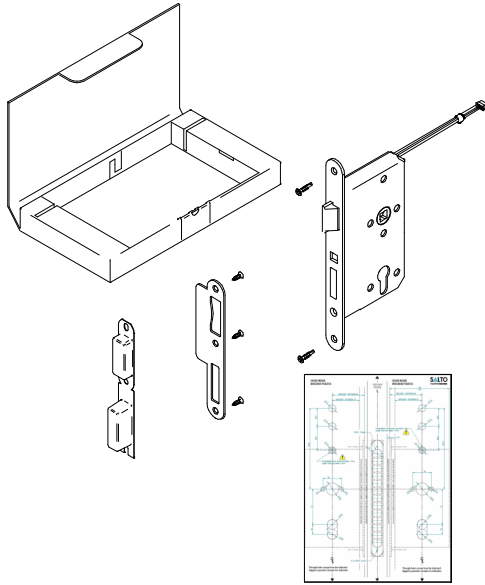

**2**

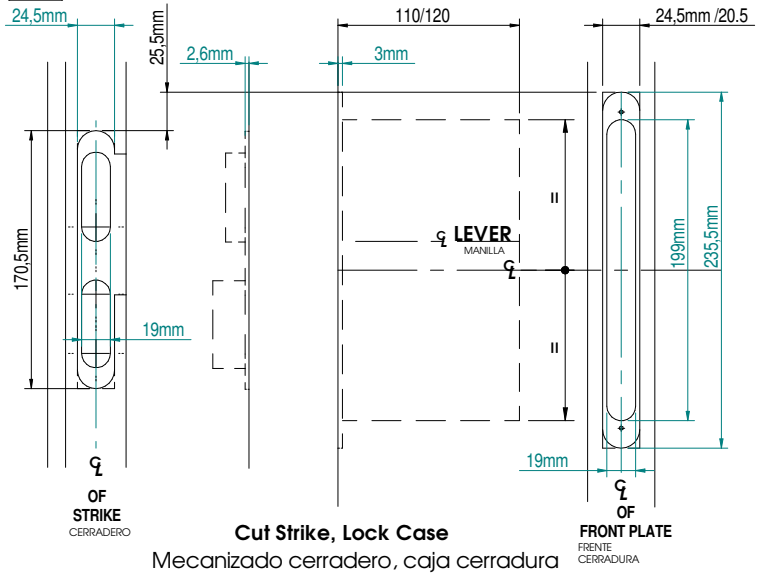

**3**

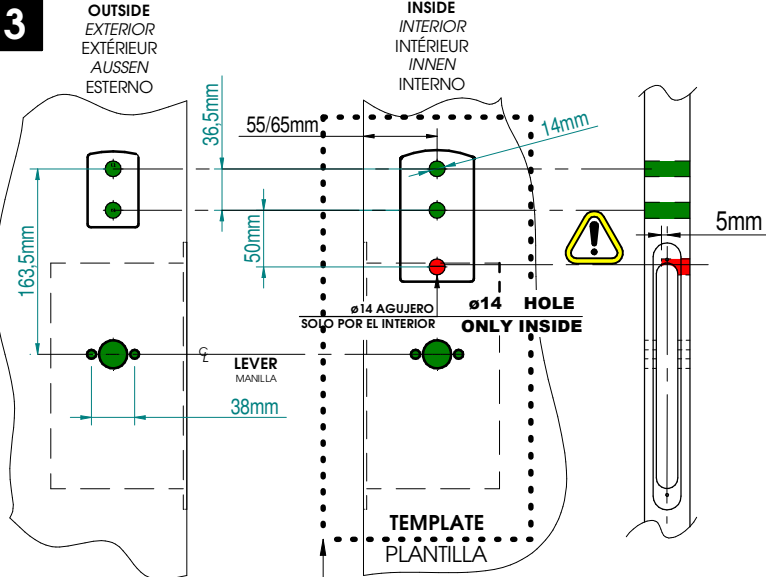

- Eng** FOR DRILLING MARKS USE TEMPLATE ONLY BY INSIDE.
- D** ZUR MARKIERUNG DER BIHRLOCHUNGEN SCHABLONE NUR AN DER INNENSEITE VERWENDEN.
- E** PARA MARCAR LOS AGUJEROS USAR LA PLANTILLA SOLO POR EL INTERIOR.
- I** PER SEGNARE LA FORATURA UTILIZZARE LA DIMA DALLA PARTE INTERNA.
- F** POUR MARQUER LES JOINTS DE PERÇAGE, N'UTILISER LE GABARIT QUE DU CÔTÉ INTERIEUR.

**4**

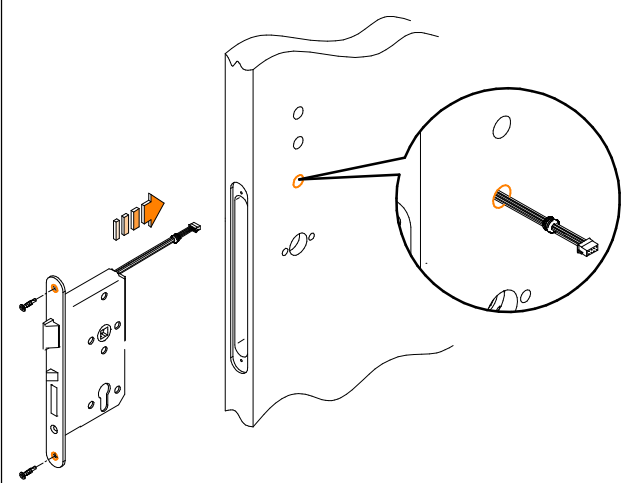

**5**

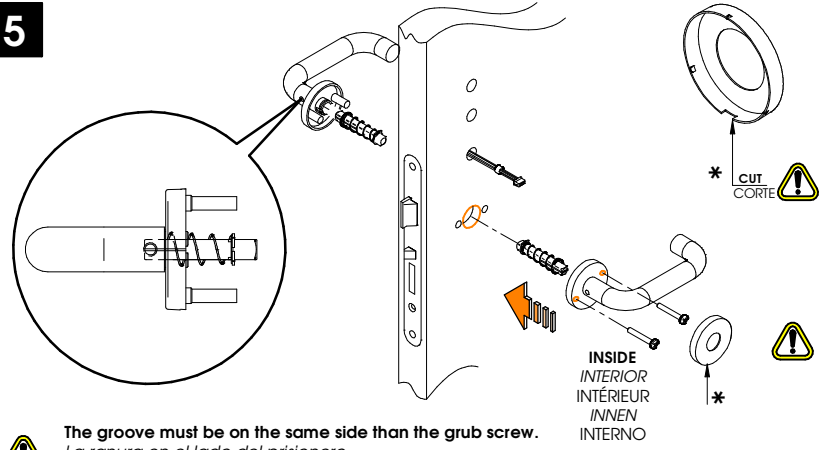

**!** The groove must be on the same side than the grub screw.  
La ranura en el lado del prisionero.  
La rainure doit être du côté de la vis.  
Nut muss an gleicher Seite wie Fixierungsschraube sein.

**6**

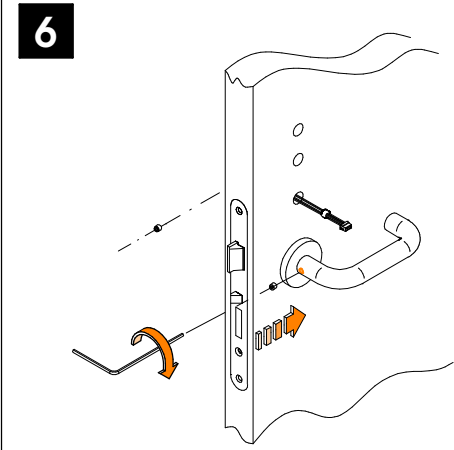

# Installation guide AELEMENT

## Euro Lock Selflocking



**SALTO**  
inspiredaccess

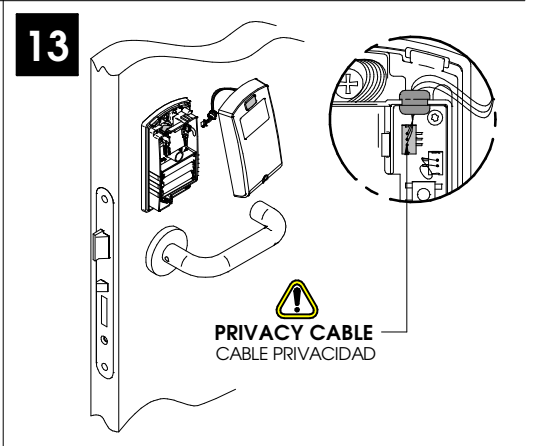
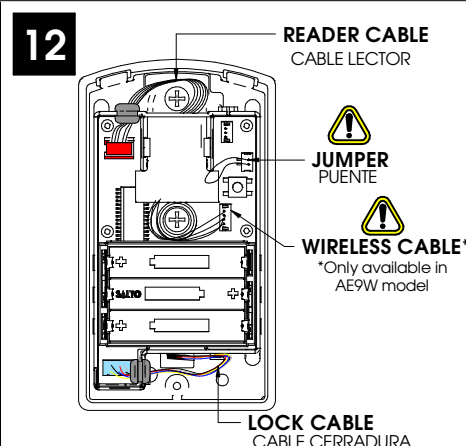
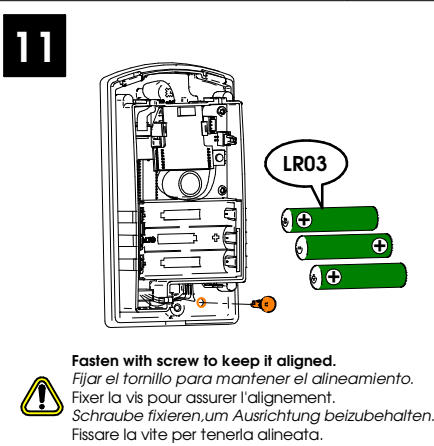
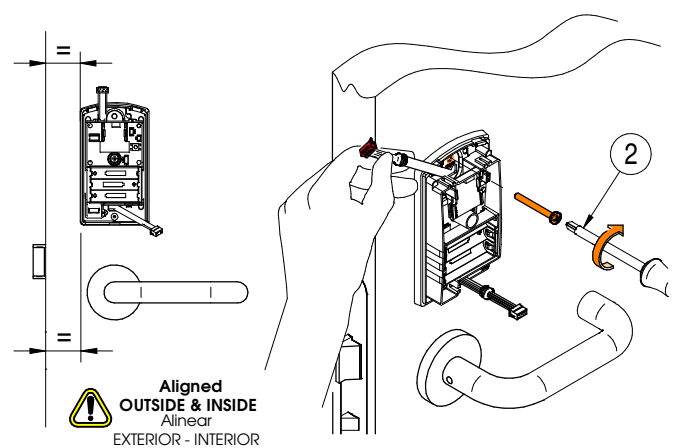
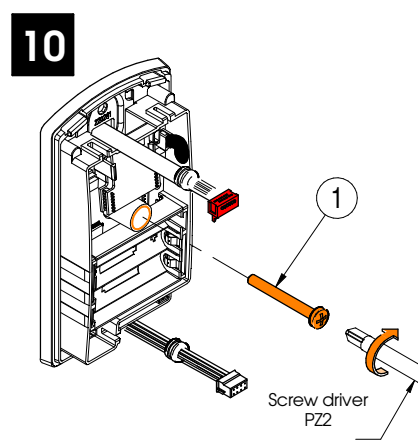
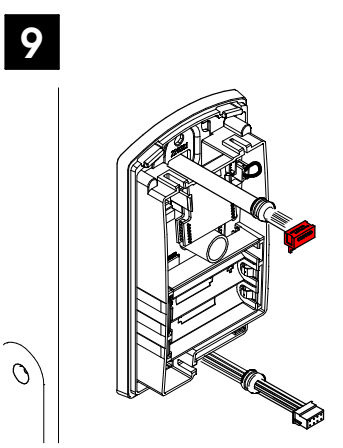
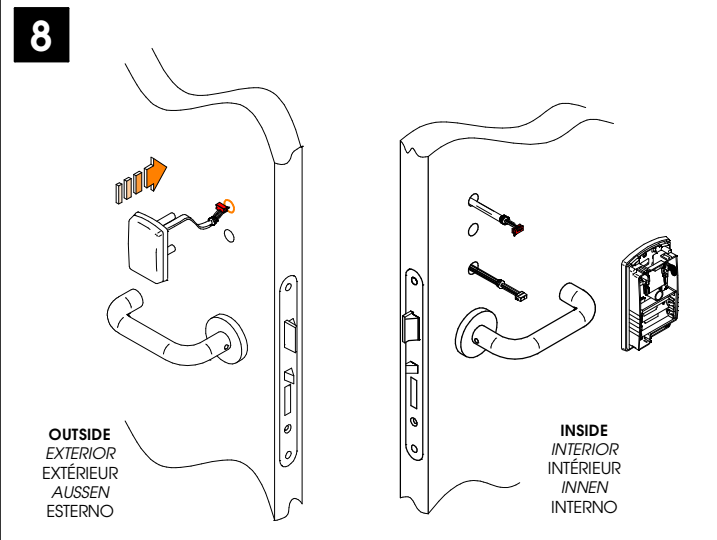
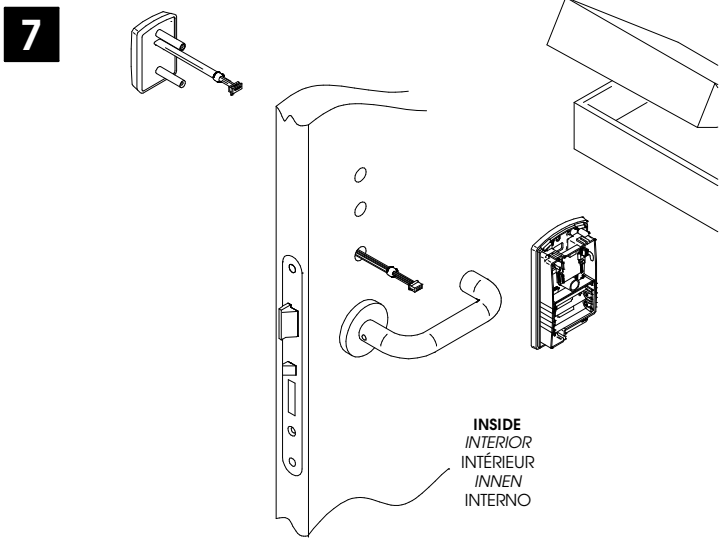

**!**

(Eng) AT THIS POINT DO NOT CLOSE THE DOOR PROGRAM THE LOCK FIRST

(E) NO CIERRE LA PUERTA. PROGRAMAR ANTES LA CERRADURA

(D) TÜRE NICHT SCHLIESSEN. ZUERST SCHLOSS PROGRAMMIEREN

(F) NE PAS FERMEZ LA PORTE DE PROGRAMMER LA SERRURE

(I) PRIMA DI CHIUDERE LA PORTA, PROGRAMMARE LA SERRATURA

Follow user manual

