

Installation guide

XS4 Original+ for EURO mortise locks & tubular latches

SALTO
inspired access

- (Eng) Installation guide
- (E) Guía de instalación
- (D) Montageanleitung
- (F) Guide d'installation
- (I) Guida all'installazione
- (P) Guia de instalação

E i 450 xx series

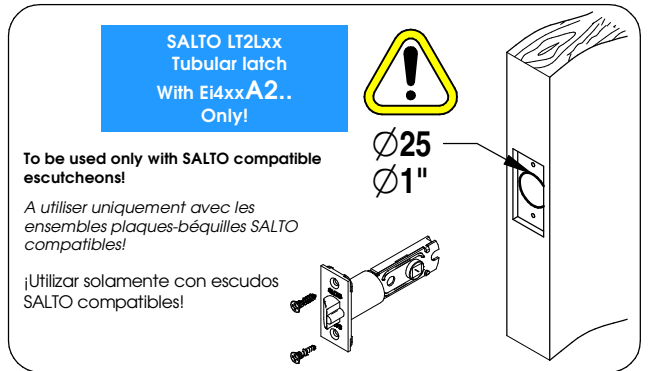
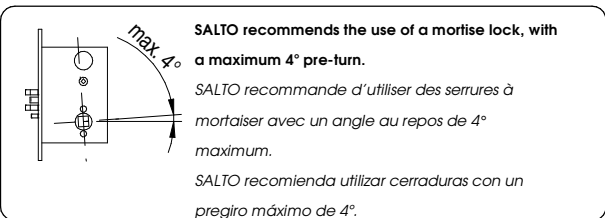
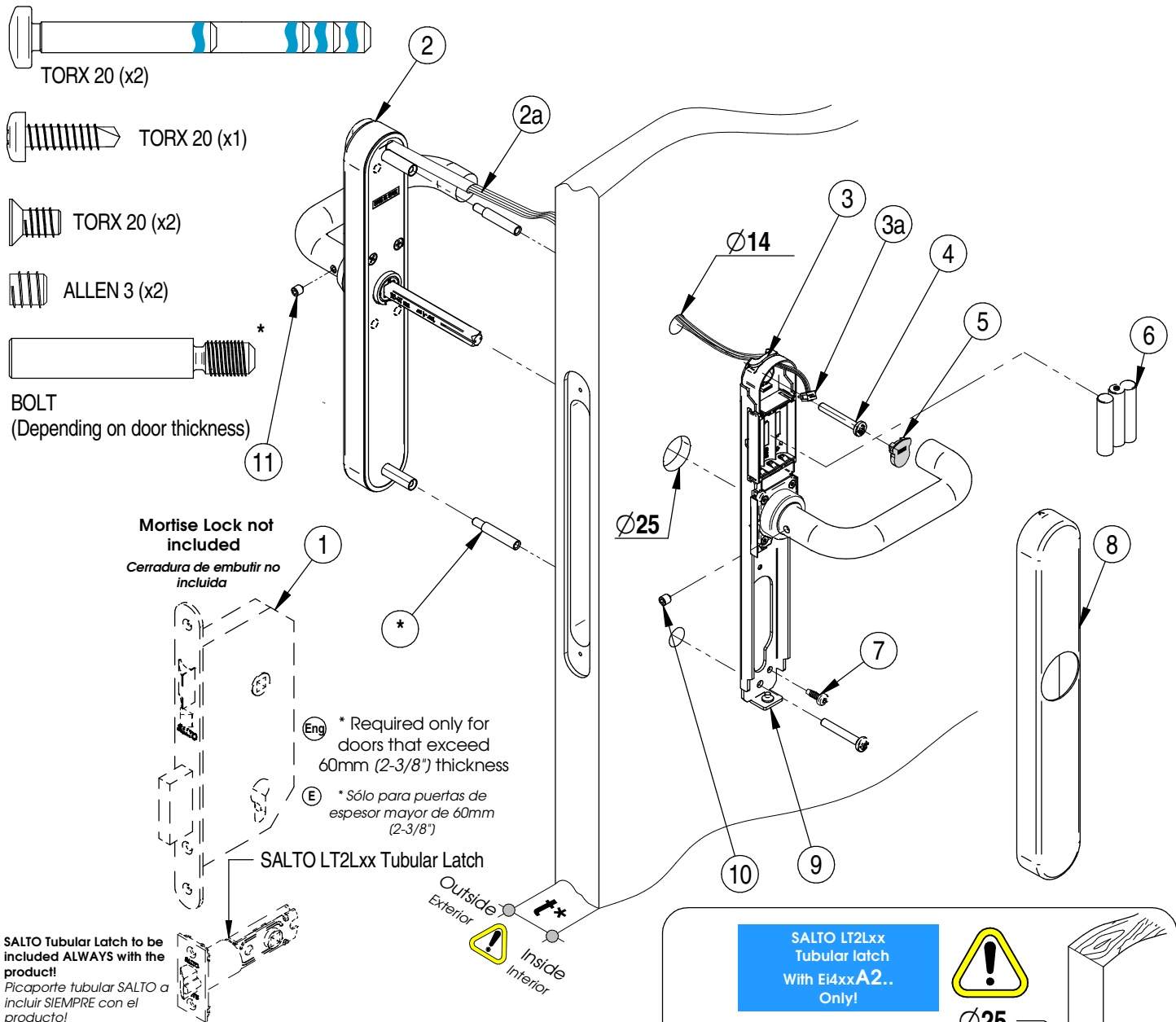
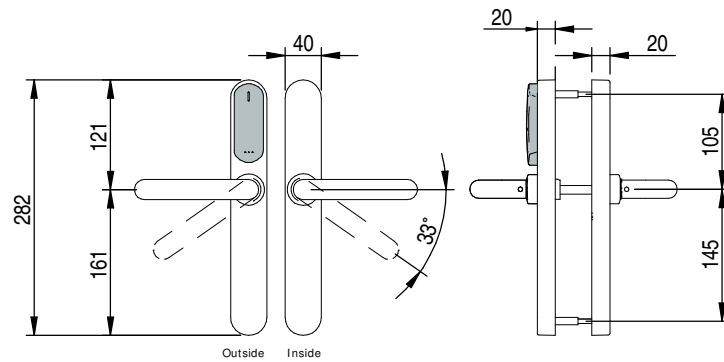

Installation guide

XS4 Original+ for EURO mortise locks & tubular latches

SALTO
inspired access

Eng Select handing (F) Choisir le sens de la bèveille (E) Seleccione mano

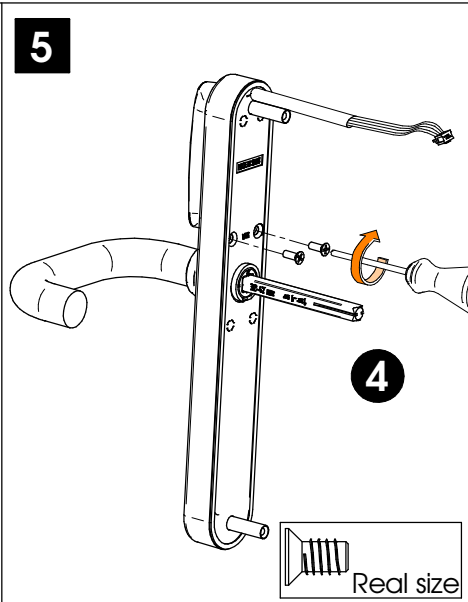
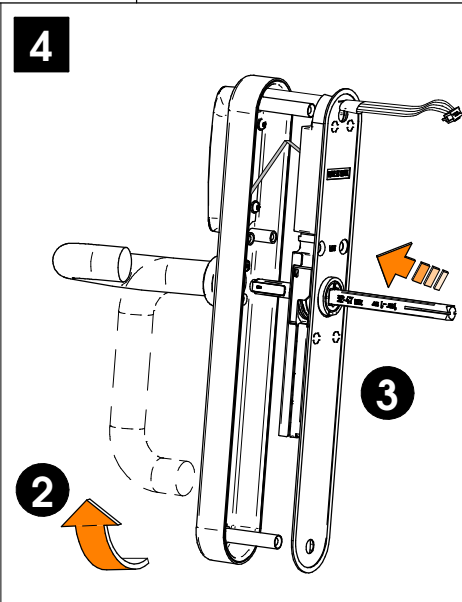
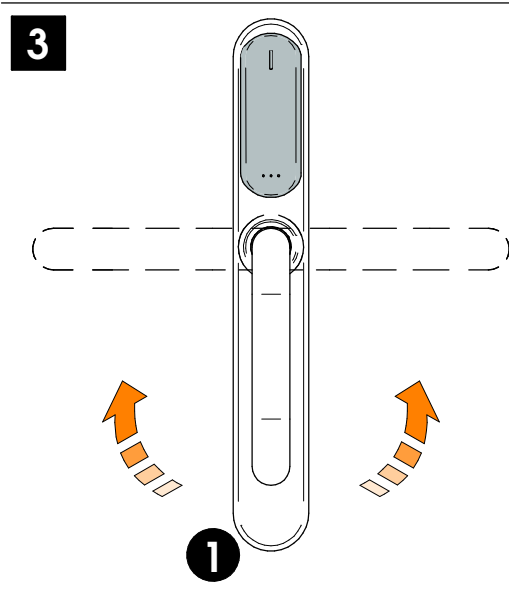
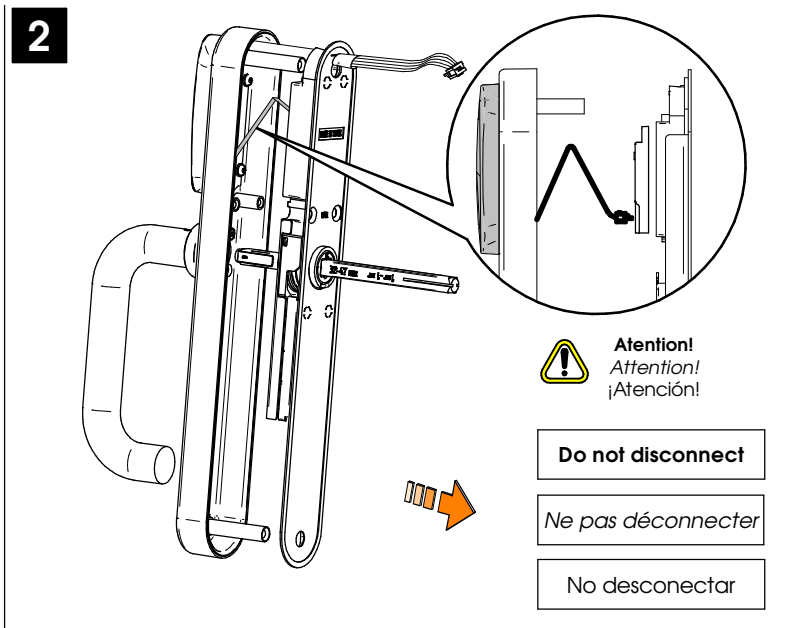
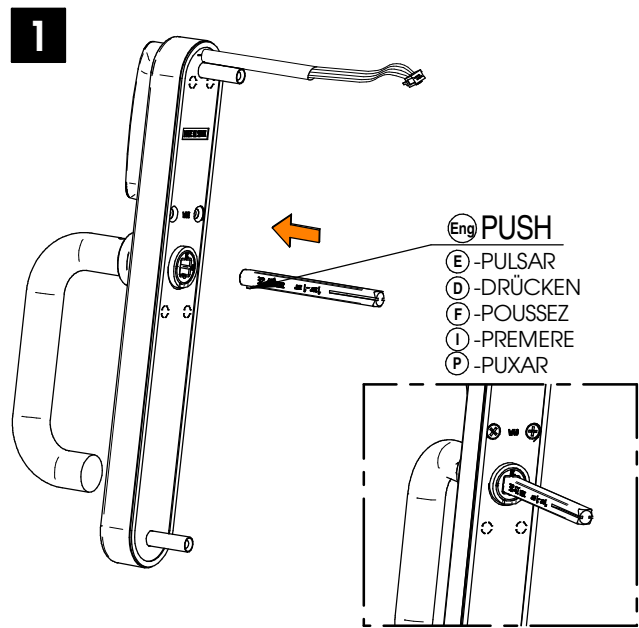

Eng Installation (F) Installation (E) Instalación

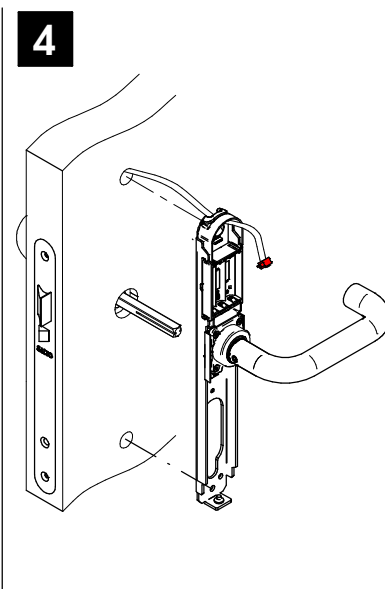
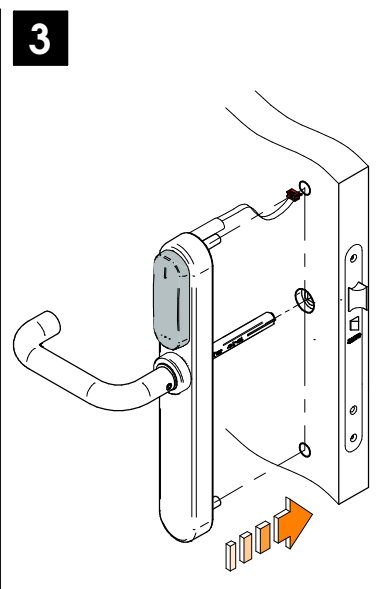
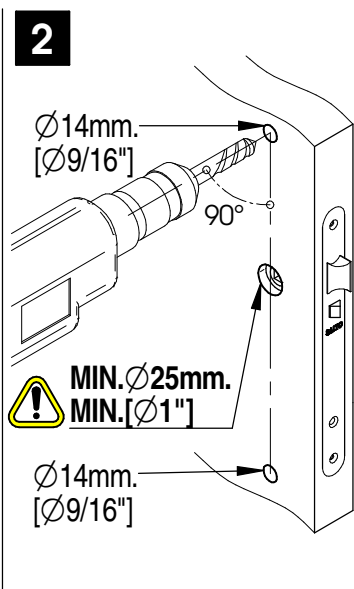
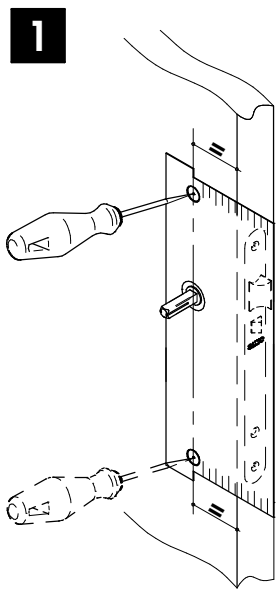

Installation guide

XS4 Original+ for EURO mortise locks & tubular latches

SALTO
inspired access

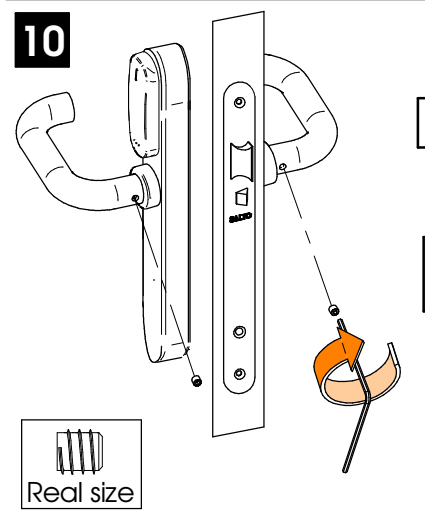
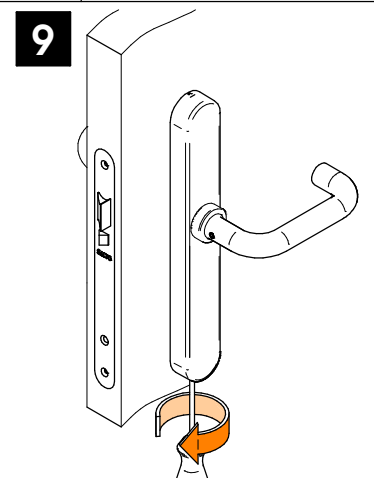
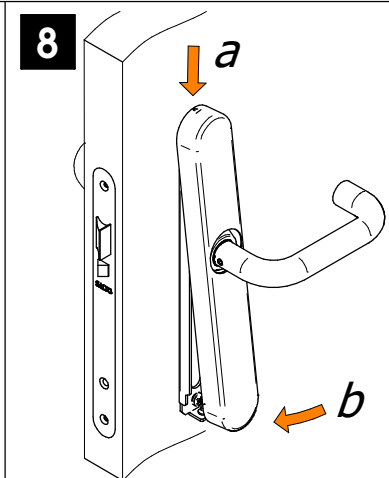
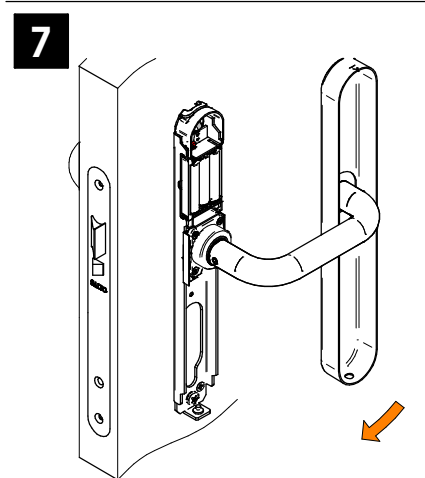
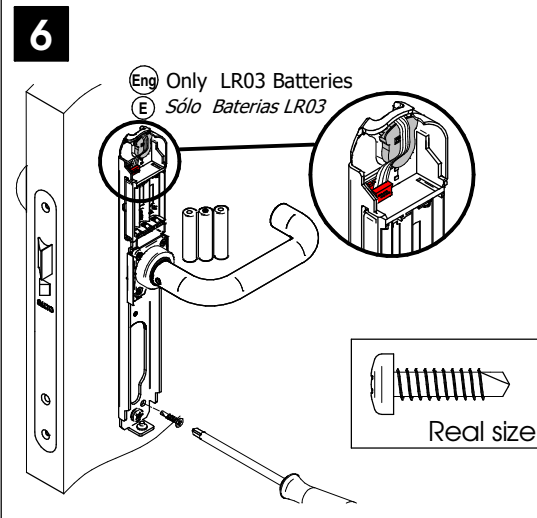
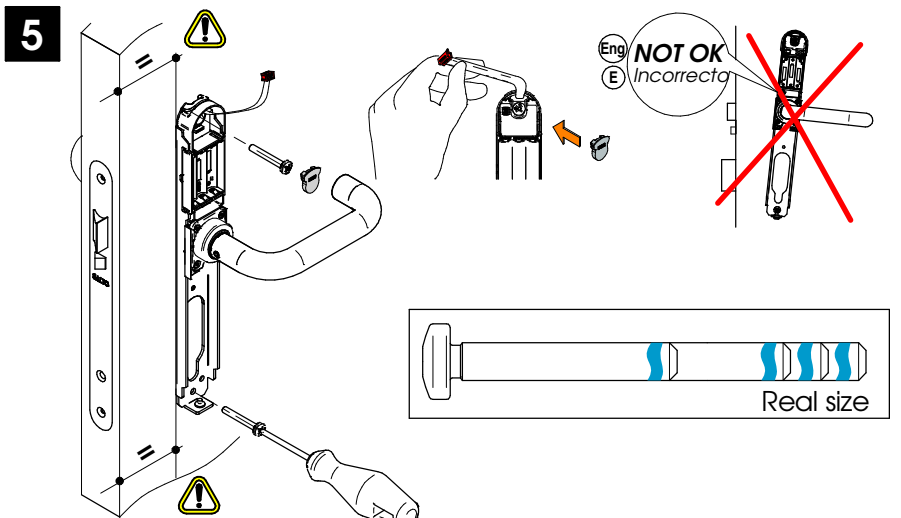

AT THIS POINT DO NOT CLOSE THE DOOR PROGRAM THE LOCK FIRST

NO CIERRE LA PUERTA. PROGRAME LA CERRADURA

TÜRE NICHT SCHLIESSEN. ZUERST SCHLOSS PROGRAMMIEREN

NE FERMEZ PAS LA PORTE. PROGRAMMEZ LA BÉQUILLE AVANT

PRIMA DI CHIUDERE LA PORTA, PROGRAMARE LA SERRATURA

NESTE PONTO NÃO FECHER A PORTA. PROGRAME O ESCUDO PRIMEIRO

Eng **Battery change**

F **Remplacer les piles**

E **Cambio de pilas**

LR03

MAX. 40'

Change/Remplacer/Cambio

Installation guide

XS4 Original+ for EURO mortise locks & tubular latches

SALTO
inspired access

Ei451 xx
Ei461 xx

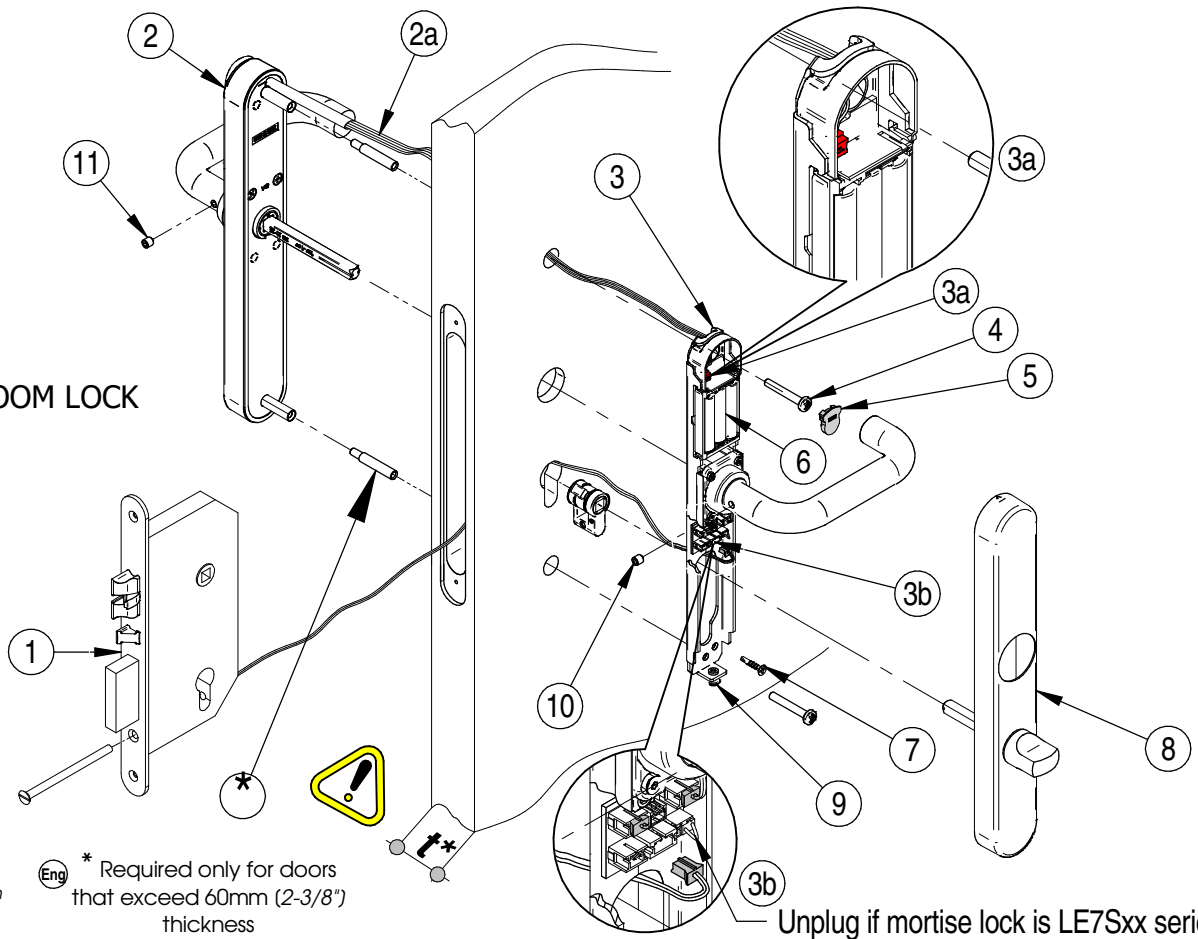
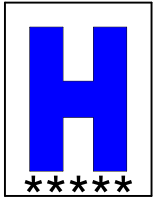

Eng HOTEL GUEST ROOM LOCK

- Ⓔ HABITACION HOTEL
- Ⓕ HOTELZIMMERSCHLOSS
- Ⓖ PIÈCE D' HÔTEL
- Ⓘ CAMERE HOTEL
- Ⓟ QUARTO DE HOTEL

Ⓔ * Sólo para puertas de espesor mayor de 60mm (2-3/8")

Ⓔ * Required only for doors that exceed 60mm (2-3/8") thickness

Unplug if mortise lock is LE7Sxx series