

KPB45xx..

XS4 OneAdapter Kit For PBA 120020/ANTIPANIC® 111 Panic Bar Mortise Lock

SALTO

inspiredaccess

Installation Sequence ① ② ③ ⑩

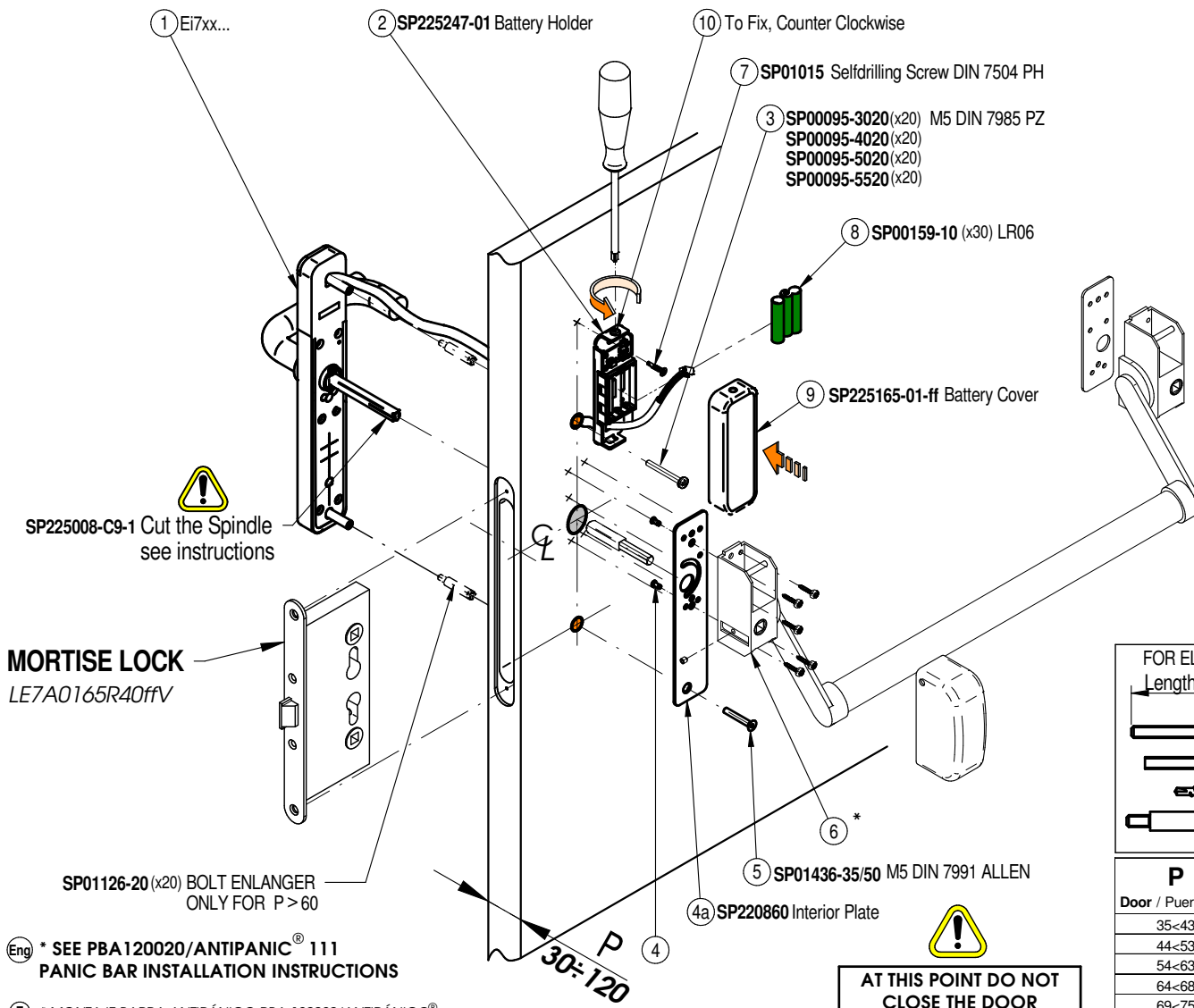

MORTISE LOCK
LE7A0165R40ffV

SP01126-20 (x20) BOLT ENLARGER
ONLY FOR P > 60

① * SEE PBA120020/ANTIPANIC® 111
PANIC BAR INSTALLATION INSTRUCTIONS

② * MONTAJE BARRA ANTIPÁNICO PBA 120020/ANTIPÁNICO®
111 SEGÚN INSTRUCCIONES DEL FABRICANTE

③ * MONTAGIO MANIGLIONI ANTIPÁNICO PBA
120020/ANTIPANIC® 111 SECONDO LE ISTRUZIONI DEL
FABRICANTE

**AT THIS POINT DO NOT
CLOSE THE DOOR
TEST THE LOCK FIRST**
follow user manual

EXTERNAL ELECTRONIC ESCUTCHEONS

LOCK	COMPATIBLE MODELS
① SERRATURE	① MODELLO COMPATIBILE
LE7A0165R40ffV	Ei750m7FffH9 Ei754m7FffH9
Type RF FIRE - 72 PZ	ONLY 9mm SPINDLE

FOR ELECTRONIC ESCUTCHEON

Length	
(1) M5 x Length DIN 7985	
(1) M5 x Length DIN 7991	
(1) Ø3,9x19 DIN 7504	
(?) BOLT EXTENSION	

P	Length	BOLT EXTENSION SUPLEMENTO
Door / Puerta mm	mm	
35<43	30	
44<53	40	
54<63	50	
64<68	55	
69<75	30	1
76<85	40	1
86<94	50	1
95<99	55	1
100<106	30	2
107<116	40	2
117<120.	50	2

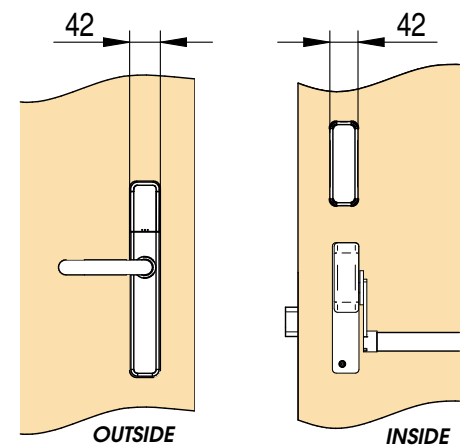

④ SALTO recommends use of the mortise lock that is recommended by the panic bar manufacturer. Some automatic locks can cause problems.
Only Wireless Models:
-Exit detection only with thru spindle.
-Locks with split hub, will cause an intrusion alarm each time the door is opened from inside.

⑤ SALTO no garantiza el correcto funcionamiento del ensamblaje, si no se utiliza la cerradura recomendada por el fabricante. Especialmente con cerraduras automáticas.
Sólo Modelos Wireless:
-Detección de salida sólo con cuadradillo pasante.
-Cerraduras con nueca partida, pueden causar una alarma de intrusión cuando la puerta sea abierta desde el interior.

All contents current at time of publication.
SALTO Systems S.L. reserves the right to change availability of any item in this catalog, its design, construction, and/or materials.

Eng ELECTRONIC ESCUTCHEON
DOOR PREPARATION

- E** MECANIZADO DE PUERTA PARA EL ESCUDO ELECTRONICO
- I** MECCANISMO DELLA PORTA PER LA PLACCA ELETTRONICA

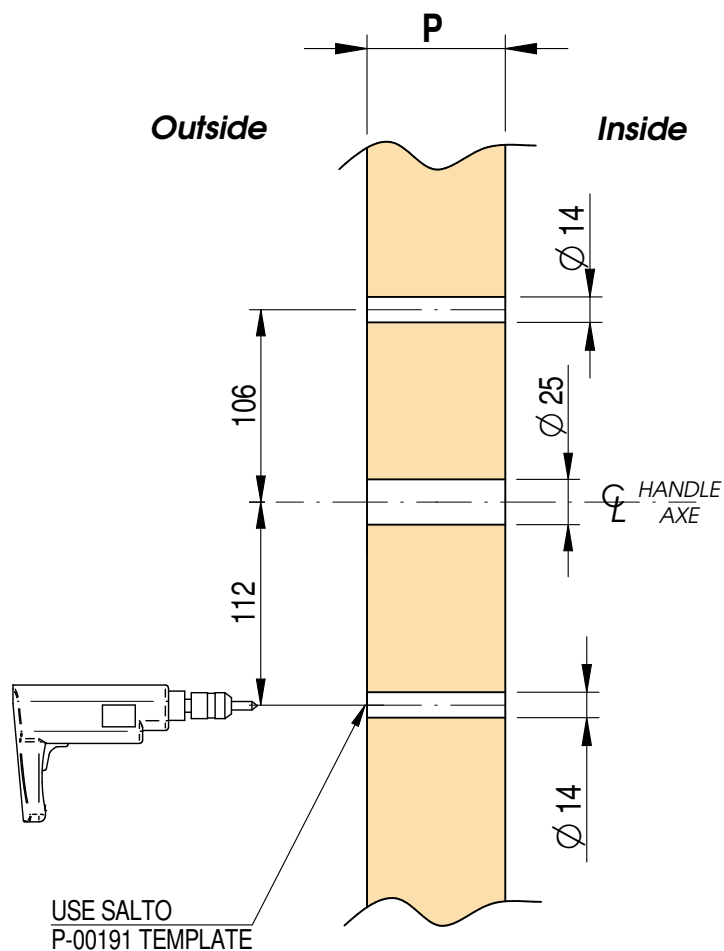

Eng MORTISE LOCK WITH SPLIT HUB

- E** CERRADURA CON NUECA PARTIDA
- I** SERRATURA PERNO QUADRO

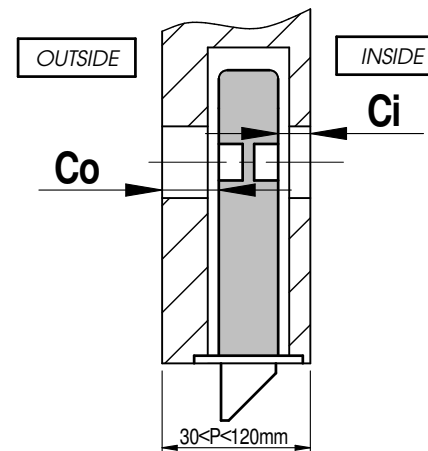

1

Eng Outside Spindle

- E** Cuadradillo Exterior
- I** Qadra esterno

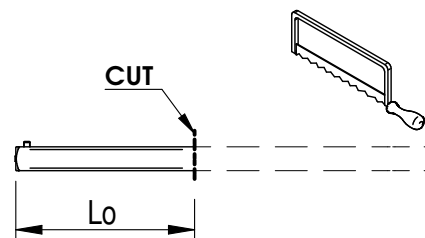

$Lo = Co + 5\text{mm}$

2

Eng Inside Spindle

- E** Cuadradillo Interior
- I** Qadra Interno

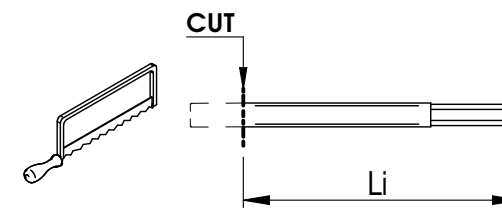

$Li = Ci + 30\text{mm}$

Eng * SEE PBA120020/ANTIPANIC® 111 PANIC BAR INSTALLATION INSTRUCTIONS

E * MONTAJE BARRA ANTIPÁNICO PBA 120020/ANTIPANIC® 111 SEGÚN INSTRUCCIONES DEL FABRICANTE

I * MONTAGIO MANIGLIONI ANTIPANICO PBA 120020/ANTIPANIC® 111 SECONDO LE ISTRUZIONI DEL FABRICANTE