

Installation guide

AElement Fusion for EURO mortise locks (LE7Sx7xx..)

SALTO

inspired access

- (Eng) Installation guide
- (F) Guide d'installation
- (E) Guía de instalación
- (D) Installationsanleitung

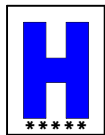

AF i 0xx.. series
 AF i 1xx.. series
 AF i 4xx.. series
 AF i 5xx.. series

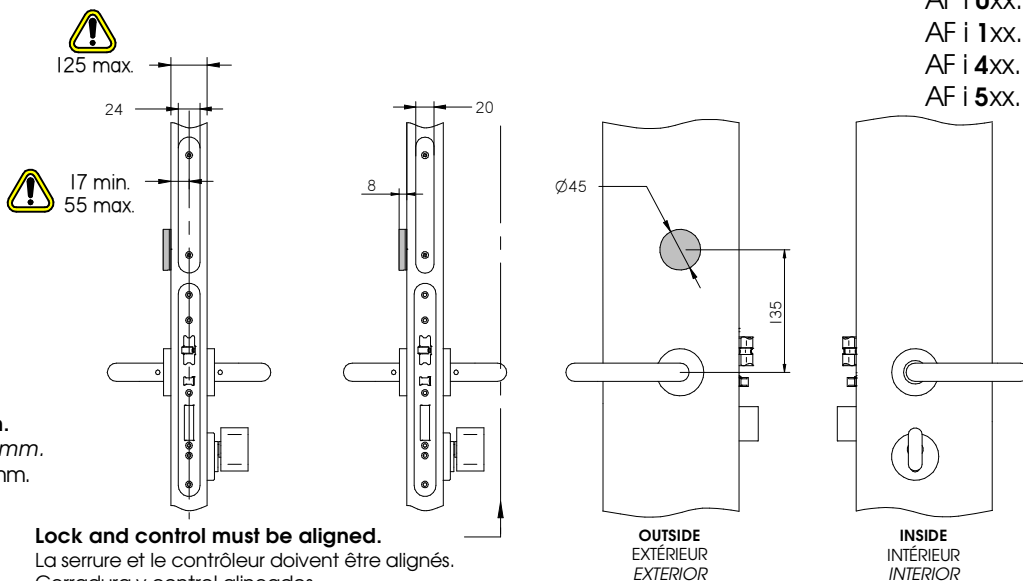

40mm < Door thickness < 125mm.
 40mm < Épaisseur d' porte < 125mm.
 40mm < Espesor de puerta < 125mm.
 40mm < Türblattstärken < 125mm.

Only SALTO spindle.
 Seulement carrés SALTO.
 Solo cuadradillos SALTO.
 Nur SALTO Vierkant.

Lock and control must be aligned.
 La serrure et le contrôleur doivent être alignés.
 Cerradura y control alineados.
 Schloss und Steuerung müssen in einer Linie ausgerichtet sein.

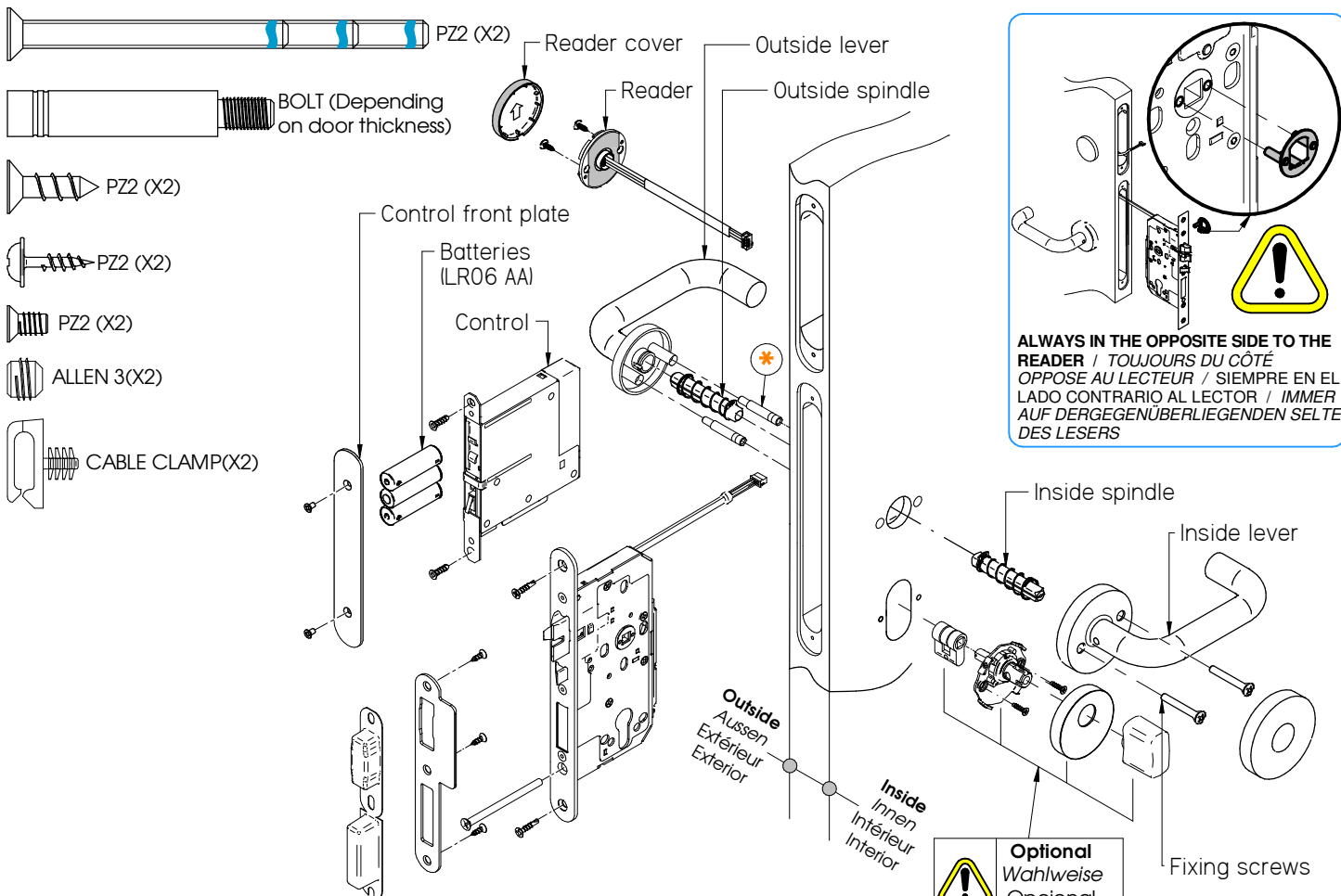

Mortise lock not included
 Serrure à mortaiser non incluse
 Cerradura de embutir no incluida
 Einsteckschloss nicht enthalten

For door preparation see: 4DS00039.
 Pour préparation de la porte, voir: 4DS00039.
 Para mecanizado de puerta, ver: 4DS00039.
 Zur Vorbereitung der Tür siehe: 4DS00039.

The mounting with other spindles voids the guaranty.
 Le montage d'autres carrés annulera le garantie.
 El montaje de otros cuadradillos anula la garantía.
 Keine Garantie bei Verwendung anderer Drückervierkante.

NOTE: Screws and spindles are included in the box of the reader.
 NOTE: Les vis et les carrés sont inclus dans la boîte du lecteur.
 NOTA: Los tornillos y cuadradillos están incluidos en la caja del lector.
 ANM: Schrauben und Drückervierkant sind in Karton des Lesers enthalten.

(*) Only for door thickness > 65mm.
 (*) Seulement pour portes de épaisseur > 65mm.
 (*) Solo para grosor de puerta > 65mm.
 (*) Nur für Türblattstärken > 65mm.

Recommendation for Customer's lever set installation on SALTO AElement. See : 4AN01299
 Recommendation pour l'installation des béquilles client sur Salto AElement. Voir: 4AN01299
 Recomendaciones para la instalación de manillas Cliente en SALTO AElement. Ver: 4AN01299
 Empfehlung zur installation von kundenspezifischem Drückernset auf SALTO AElement. Sehen: 4AN01299.

Installation guide

Ælement Fusion for EURO mortise locks (LE7Sx7xx..)

SALTO
inspired access

Eng Installation F Installation E Instalación D Installation

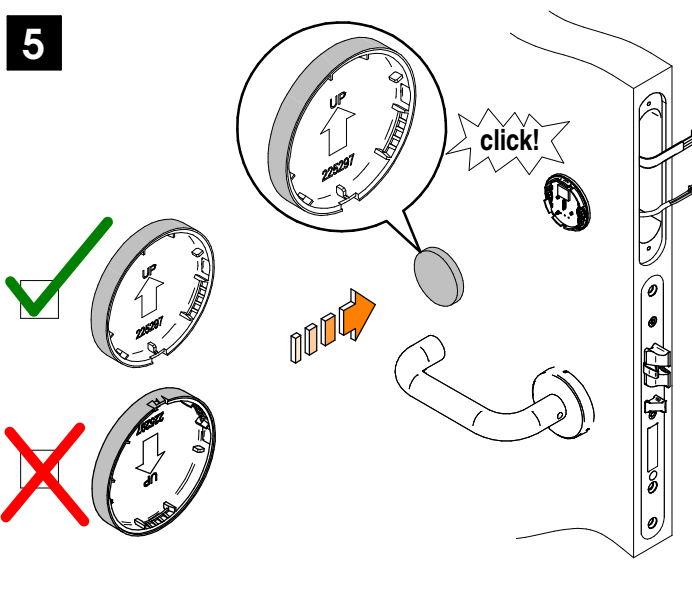
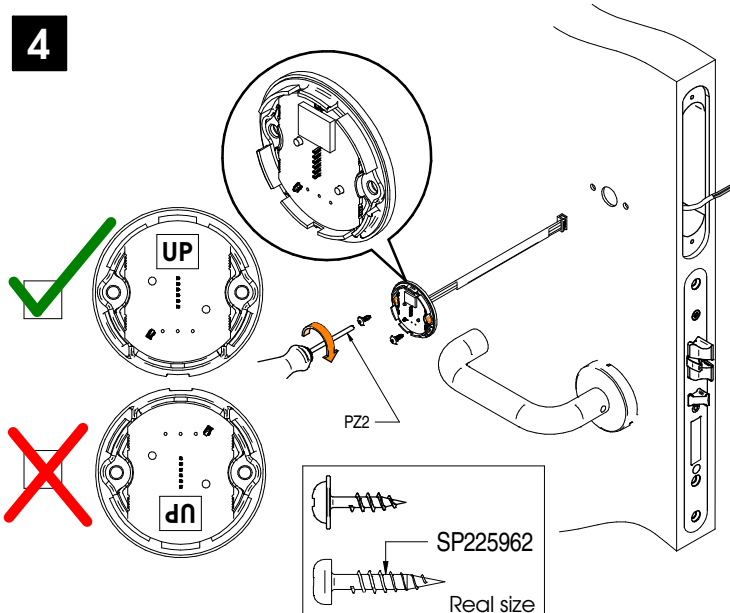
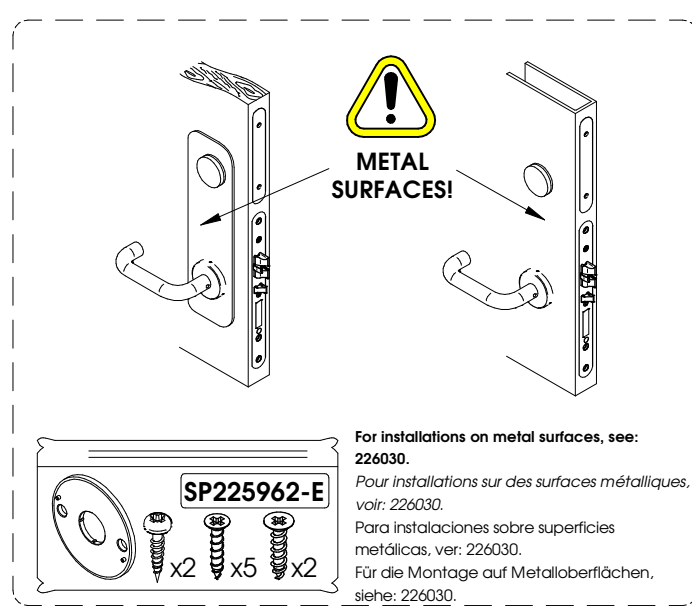
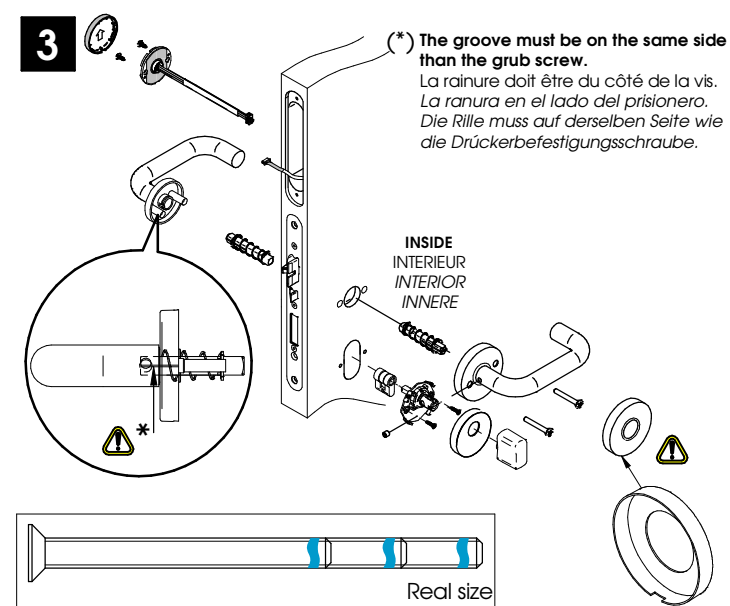
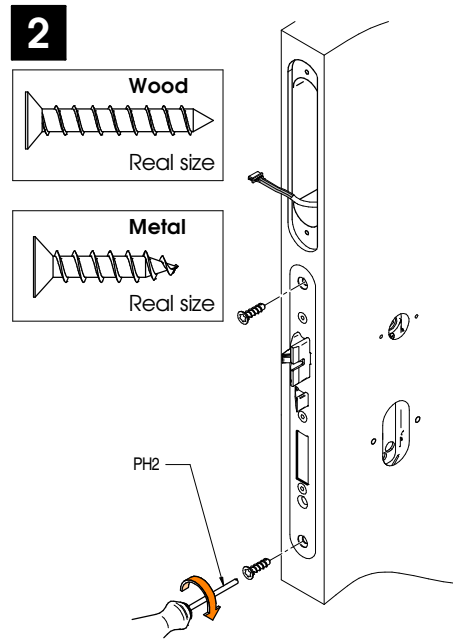
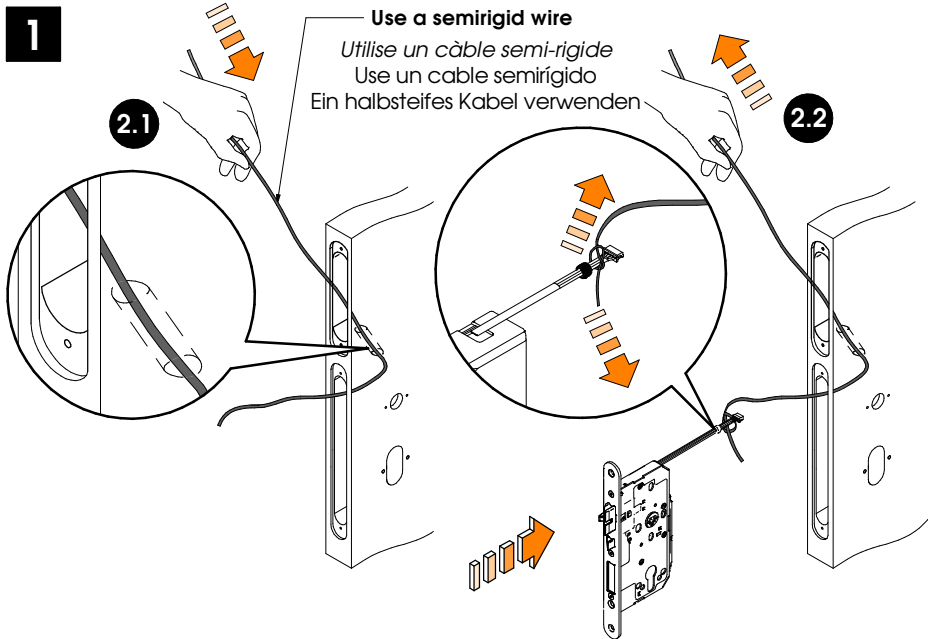

Installation guide

Ælement Fusion for EURO mortise locks (LE7Sx7xx..)

SALTO
inspiredaccess

Eng Cable connection **F** Câble de raccordement **E** Conexión cableado **D** Kabelverbindung



Select an option depending on the position of the reader (a or b).
Sélectionnez une option en fonction de la position du lecteur (a ou b).
Seleccionar una opción dependiendo de la posición del lector (a ó b).
Wählen Sie eine option abhängig von der position des Lesers (a oder b).

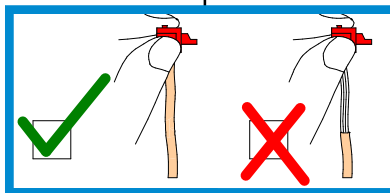
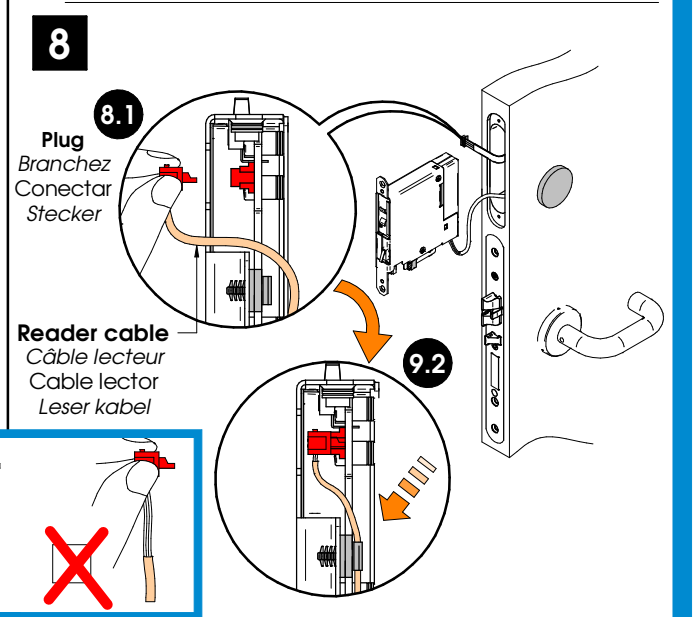
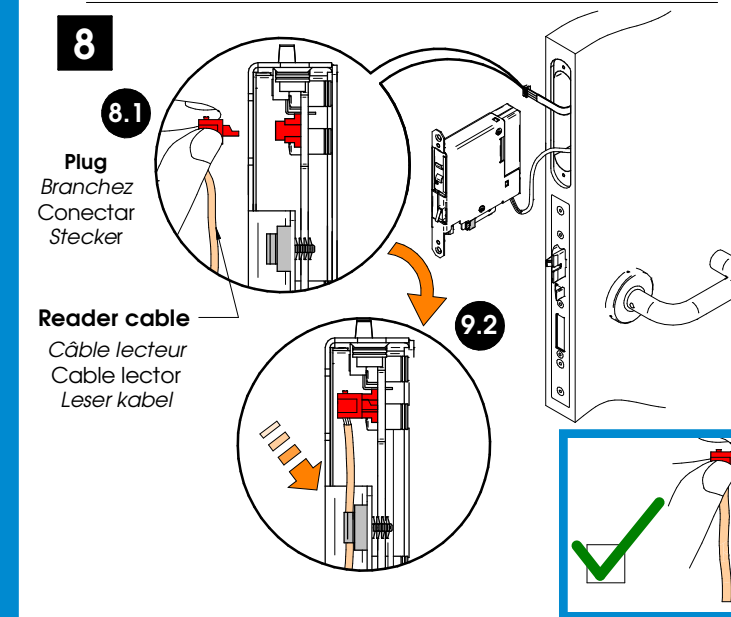
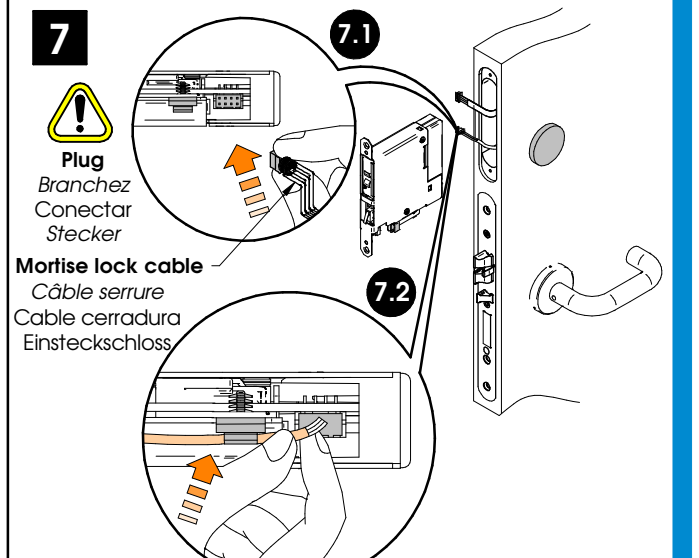
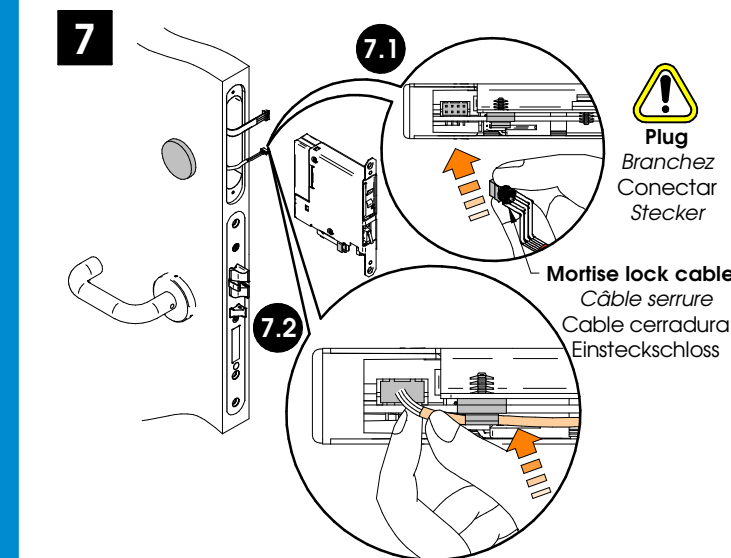
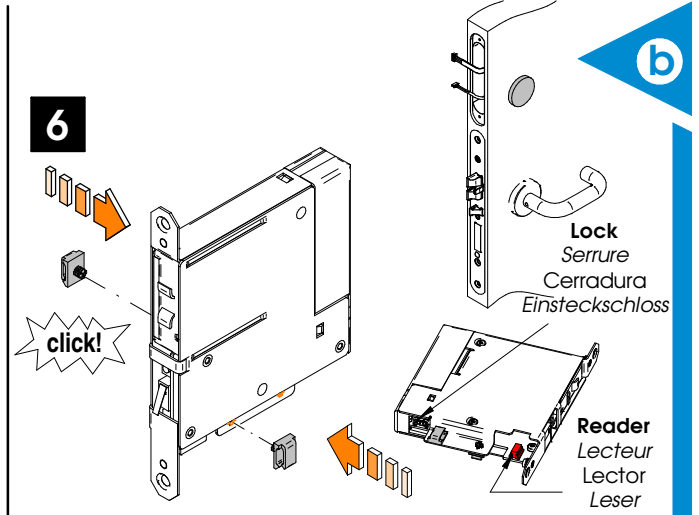
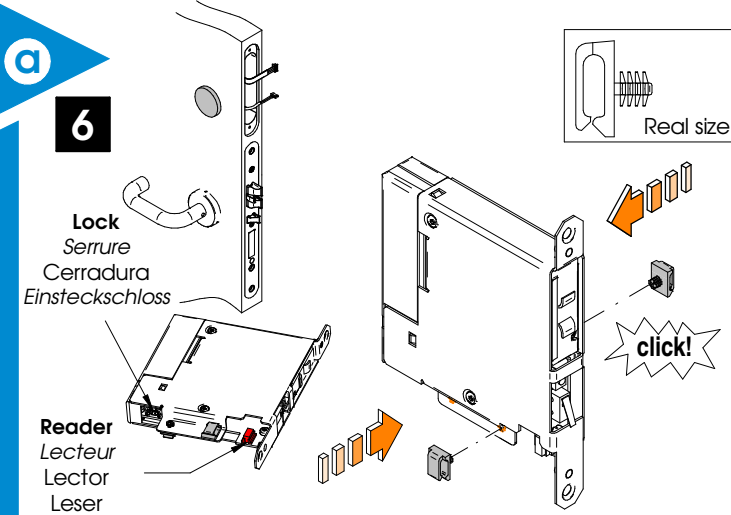

Installation guide

ÆElement Fusion for EURO mortise locks (LE7Sx7xx..)

SALTO
inspiredaccess

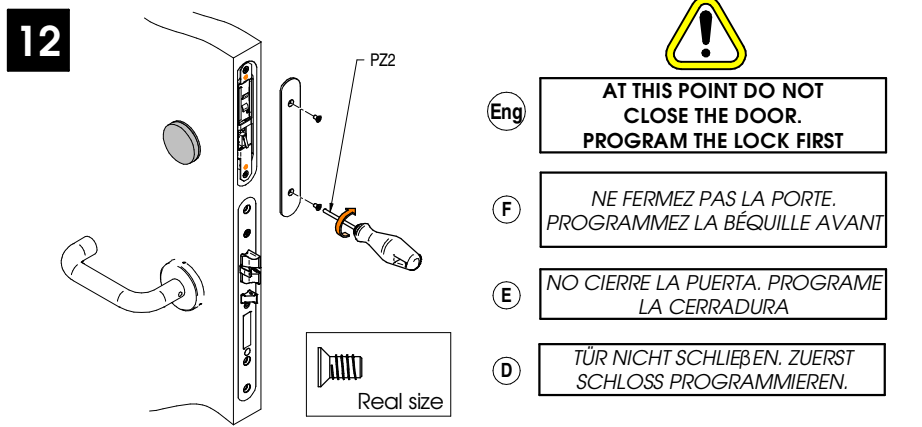
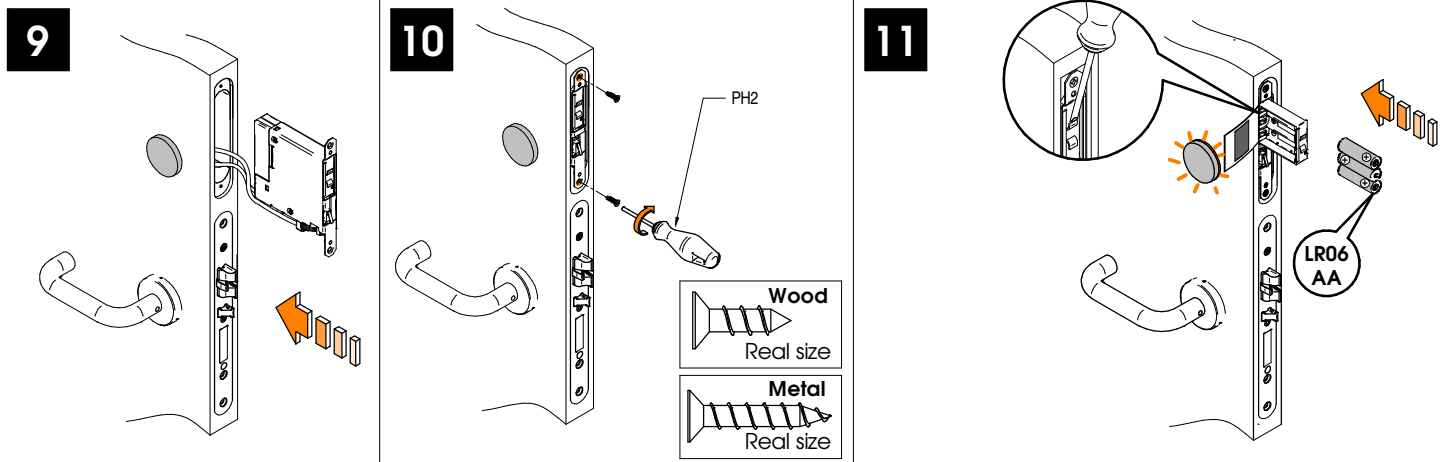

Eng Emergency opening **F** Ouverture d'urgence **E** Apertura emergenciac **D** Notöffnung

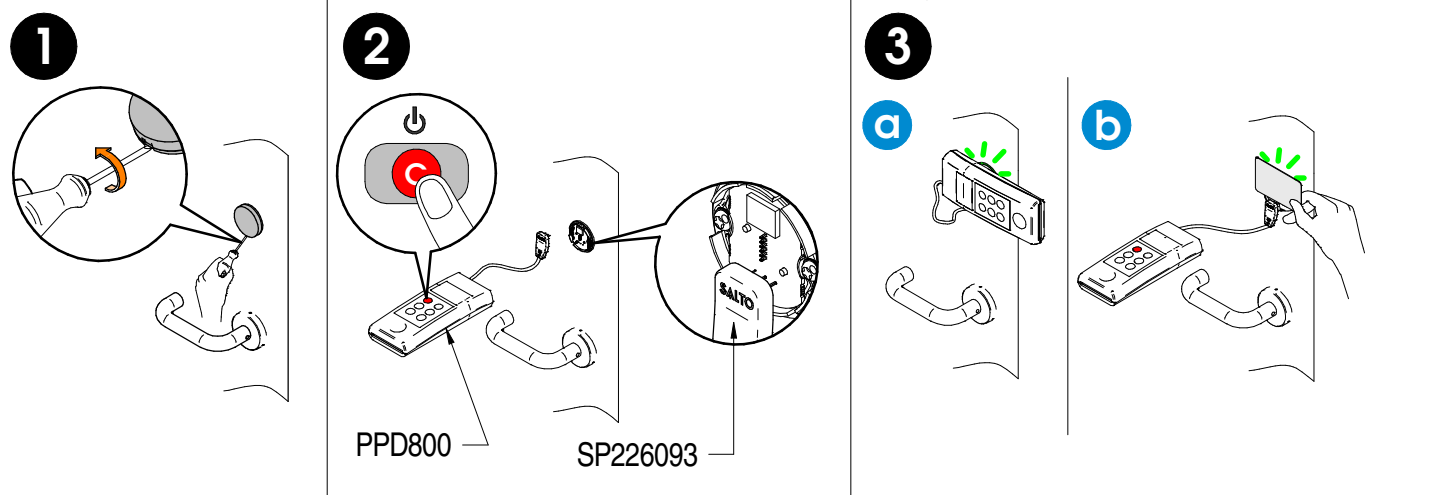

Eng Use/maintenance **F** L'utilisation/l'entretien **E** Uso/mantenimiento **D** Benutzung/Wartung

Operating conditions: 0°C < t < 60°C.
 Condition de fonctionnement: 0°C < t < 60°C.
 Condiciones de funcionamiento: 0°C < t < 60°C.
 Bedingungen für den Betrieb: 0°C < t < 60°C.

To use in non condensing environments.
 Pour des environnement sans condensation.
 Para uso en entornos sin condensación.
 Zum Gebrauch in nicht-kondensierenden Umgebungen.

