

PROGRAMMA CAP



Rosselló Nº 21
08029 - BCN
936 002 002
info@arcon.es
www.arcon.es



ALLUMINIO EN-AW 6060 - ALUMINUM ALLOY EN-AW 6060 - ALUMINIUM EN-AW 6060 - ALUMINIO EN-AW 6060

LA LEGA DI ALLUMINIO EN-AW 6060 È UNA LEGA A MEDIA RESISTENZA, HA UN'OTTIMA RESISTENZA ALLA CORROSIONE, OTTIMA SALDABILITÀ E BUONA RESISTENZA ALLE BASSE TEMPERATURE. È COMUNEMENTE USATA PER REALIZZARE ELEMENTI ANCHE CON FORMA COMPLESSA E RISULTA MOLTO BUONA NEI PROCESSI DI ANODIZZAZIONE.

THE ALUMINUM EN-AW 6060 ALLOY HAS AN EXCELLENT RESISTANCE TO CORROSION, TO LOW TEMPERATURES AND ALLOWS QUALITY WELDINGS. IN THE DESIGN WORLD IT IS COMMONLY USED TO CREATE COMPONENTS WITH COMPLEX SHAPES ALLOWING EXCELLENT QUALITY RESULTS COMPARED TO OTHER ALLOYS FOR ANODIZING TREATMENTS.

L'ALLIAGE D'ALUMINIUM EN-AW 6060 EST UN ALLIAGE POUVANT ÊTRE TRAITÉ THERMIQUEMENT DE RÉSISTANCE MOYENNE. IL PRÉSENTE UNE TRÈS BONNE RÉSISTANCE À LA CORROSION, UNE TRÈS BONNE SOUDABILITÉ ET UNE BONNE FORMABILITÉ À FROID. IL EST COURAMMENT UTILISÉ POUR LES SECTIONS COMPLEXES ET PRÉSENTE UNE TRÈS BONNE RÉPONSE AU PROCESSUS D'ANODISATION.

LA ALEACIÓN DE ALUMINIO EN-AW 6060 ES UNA ALEACIÓN QUE SE PUEDE TRATAR CON CALOR DE RESISTENCIA MEDIA. TIENE MUY BUENA RESISTENCIA A LA CORROSIÓN, MUY BUENA SOLDABILIDAD Y BUENA CONFORMABILIDAD EN FRÍO. SE USA COMÚNMENTE PARA CORTES TRANSVERSALES COMPLEJOS Y TIENE UNA RESPUESTA DE ANODIZACIÓN MUY BUENA.

STANDARD

.30
BIANCO
WHITE
BLANC
BLANCO

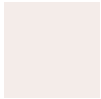

RAIL
 Coated aluminum
ACCESSORIES
 Coated aluminum
SUPPORT AND BENDS
 Coated aluminum

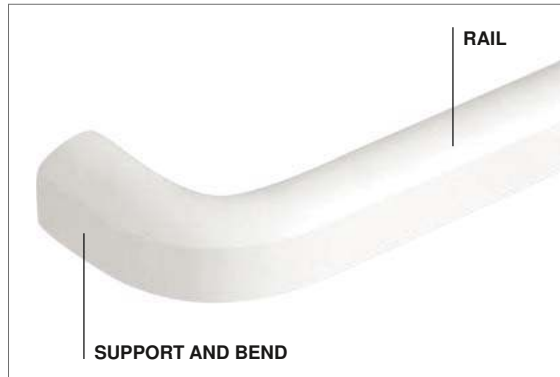

.24
GRIGIO CHIARO
LIGHT GREY
GRIS CLAIR
GRIS CLARO

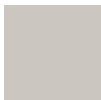

RAIL
 Coated aluminum
ACCESSORIES
 Coated aluminum
SUPPORT AND BENDS
 Coated aluminum

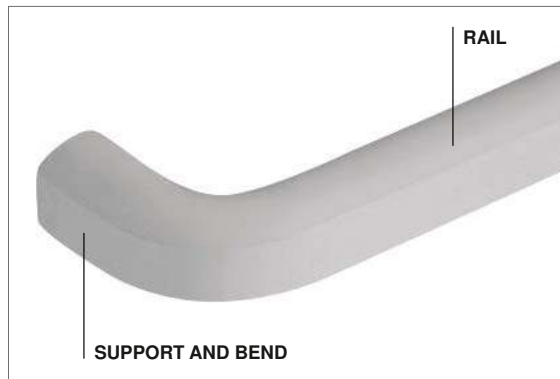

UPON REQUEST - ON MINIMUM LOT TO BE AGREED

.40
NERO
BLACK
NOIR
NEGRO



RAIL
 Coated aluminum
ACCESSORIES
 Coated aluminum
SUPPORT AND BENDS
 Coated aluminum

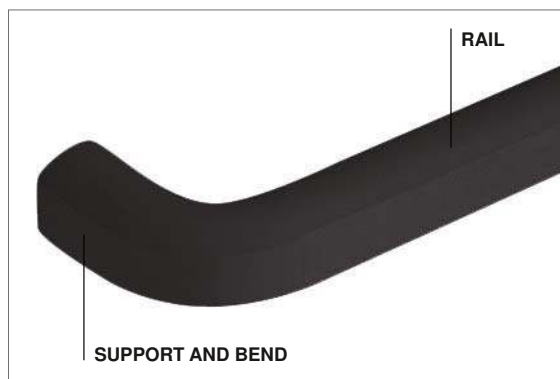

SOSTEGNI DI SICUREZZA
SAFETY SUPPORTS
BARRES D'APPUI
ASIDEROS

Page 154



AUSILI DI SICUREZZA RIBALTABILI
LIFT-UP SAFETY SUPPORTS
BARRES D'APPUI RELEVABLES
ASIDEROS ABATIBLES

Page 162

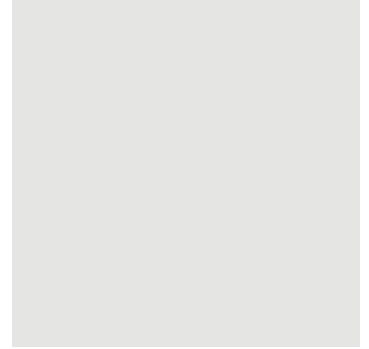

SEGGIOLINI
SEATS
SIÈGES
ASIENTOS

Page 164

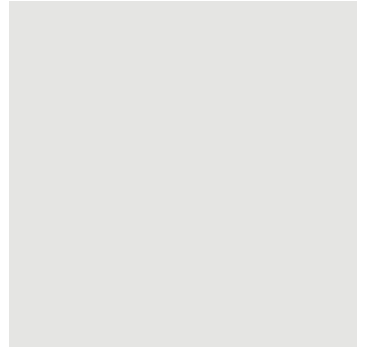
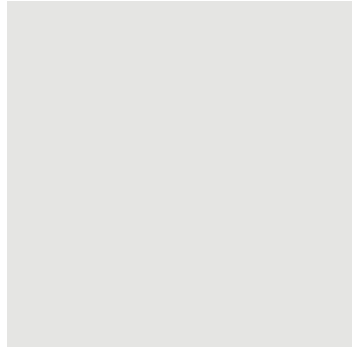

ACCESSORI BAGNO
BATHROOM ACCESSORIES
ACCESSOIRES DE BAIN
ACESORIOS DE BAÑO

Page 166



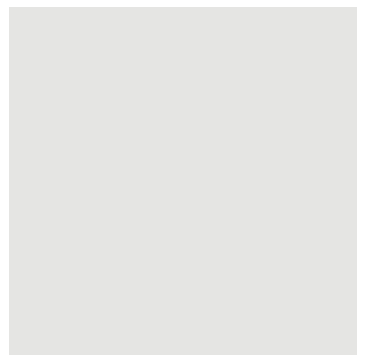
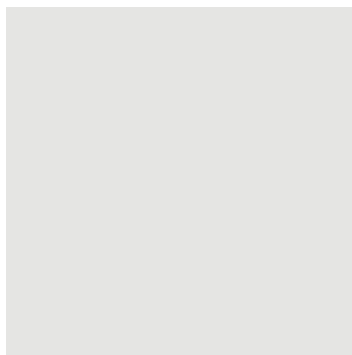
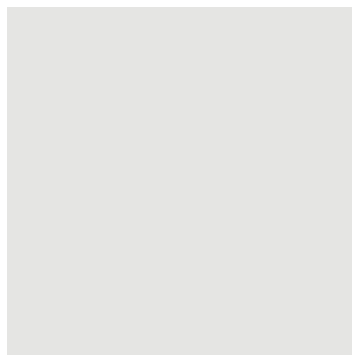
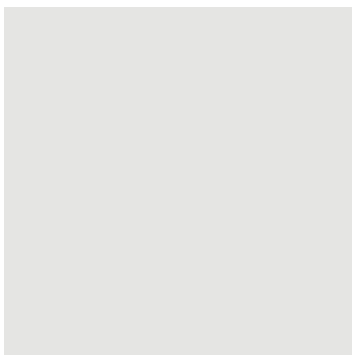
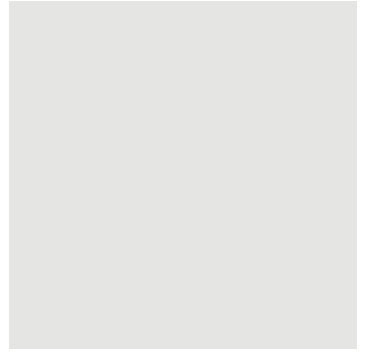
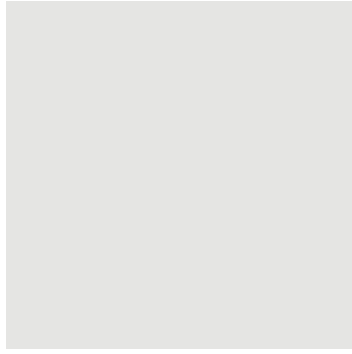
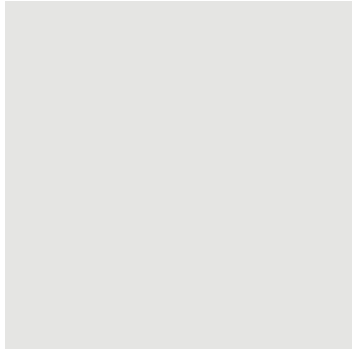
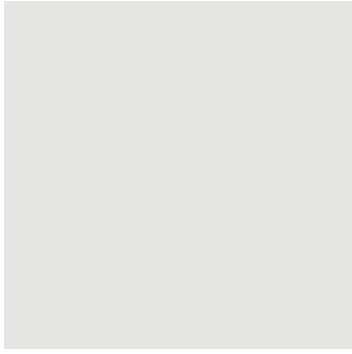
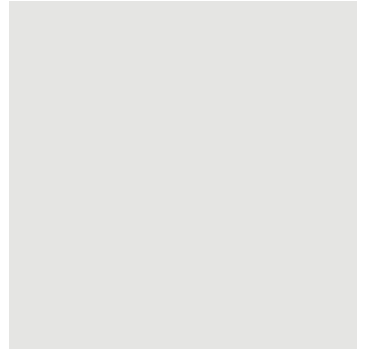
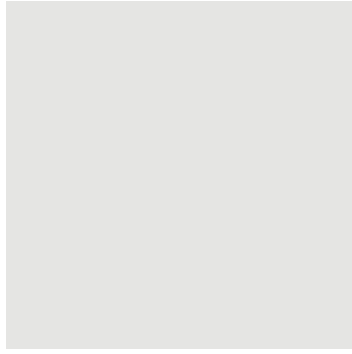
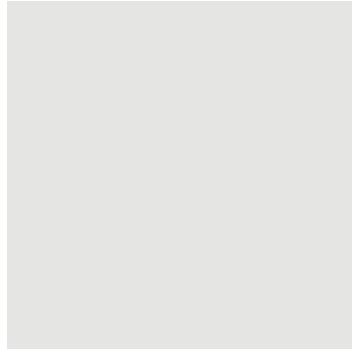
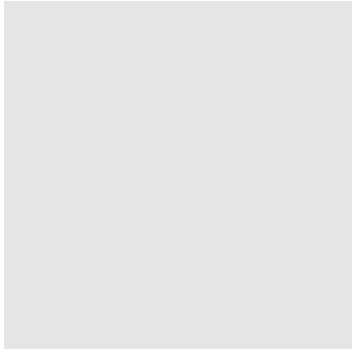
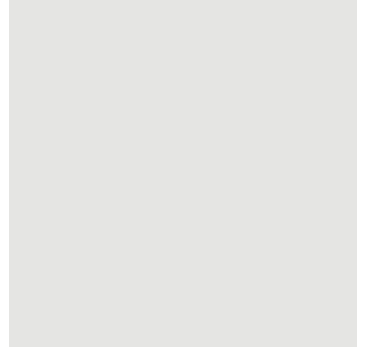
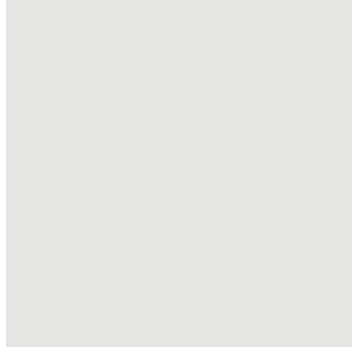
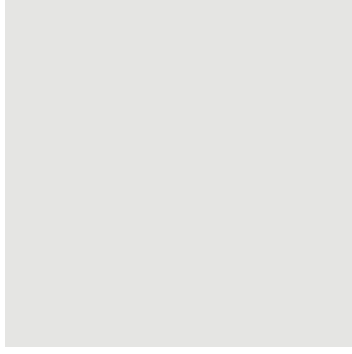
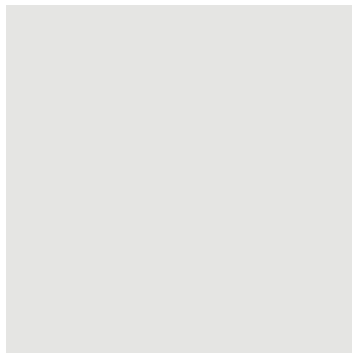
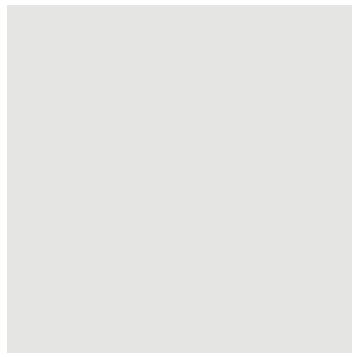
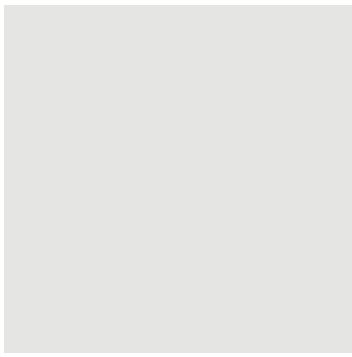





◆ RIGHT



ART.	◆	A	B
CAP.422.0000 .xx .x		220 (252)*	520 (552)*
☞ CAP.22J.0000 .xx .x			
CAP.422.000M .xx .x		300 (332)*	520 (552)*
☞ CAP.22J.000M .xx .x			
CAP.422.000L .xx .x		320 (352)*	720 (752)*
☞ CAP.22J.000L .xx .x			
CAP.422.00LA .xx .x		400 (432)*	1160 (1192)*
☞ CAP.22J.00LA .xx .x			
CAP.422.9999 .xx .x	Ⓢ		Ⓢ
☞ CAP.22J.9999 .xx .x			

ART.	A	B
CAP.433.0000 .xx	1570 (1600)*	820 (852)*
☞ CAP.33J.0000 .xx		
CAP.433.9999 .xx	Ⓢ	Ⓢ
☞ CAP.33J.9999 .xx		

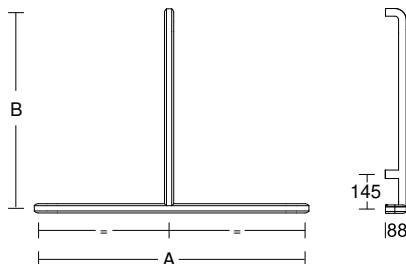
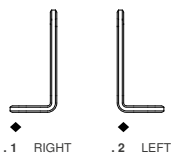
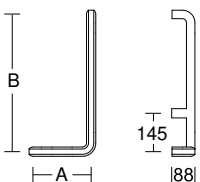

- Sostegno di sicurezza a "L"
- "L"-shaped safety support
- Barre d'appui forme à "L"
- Asidero en "L"



- Sostegno di sicurezza a "T"
- "T"-shaped safety support
- Barre d'appui forme à "T"
- Asidero en "T"



.XX FINISH .30 .24

◆
 .1 DESTRO RIGHT DROITE DERECHA
 .2 SINISTRO LEFT GAUCHE IZQUIERDA



◆ LEFT

ART.	◆	A	B	C
CAP.424.0000 .xx .x		660 (676)*	660 (678)*	820 (852)*
☞ CAP.24J.0000 .xx .x				
CAP.424.000L .xx .x		760 (776)*	400 (418)*	1160 (1192)*
☞ CAP.24J.000L .xx .x				
CAP.424.00LA .xx .x		760 (776)*	760 (778)*	1160 (1192)*
☞ CAP.24J.00LA .xx .x				
CAP.424.9999 .xx .x	Ⓢ			
☞ CAP.24J.9999 .xx .x				

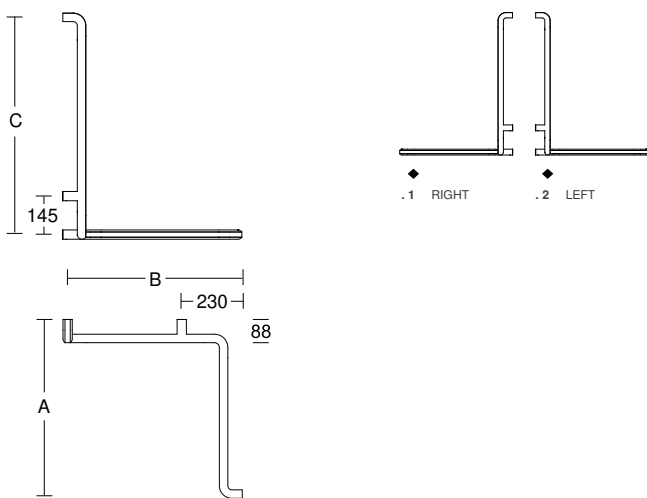

- Sostegno di sicurezza ad angolo con impugnatura verticale
- Corner shower rail with shower head rail
- Barre d'appui à coin avec barre de douche
- Asidero en ángulo con empuñadura vertical



◆ LEFT

ART.	◆	A	B	C
CAP.443.000B .xx .x		760 (776)*	760 (776)*	1160 (1192)*
☞ CAP.43J.000B .xx .x				
CAP.443.00BL .xx .x		760 (776)*	1184 (1200)*	1160 (1192)*
☞ CAP.43J.00BL .xx .x				
CAP.443.999B .xx .x	Ⓢ			
☞ CAP.43J.999B .xx .x				

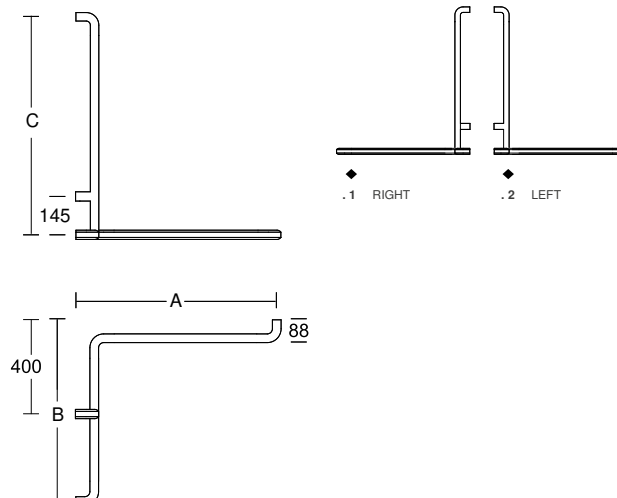

- Sostegno di sicurezza ad angolo con impugnatura verticale
- Corner shower rail with shower head rail
- Barre d'appui à coin avec barre de douche
- Asidero en ángulo con empuñadura vertical



.XX FINISH
 .30
 .24

◆
 .1 DESTRO RIGHT DROITE DERECHA
 .2 SINISTRO LEFT GAUCHE IZQUIERDA



ART.	A
CAP.487.0000 . xx	570 (600)*
CAP.487.000A . xx	770 (800)*
CAP.487.000B . xx	970 (1000)*
CAP.487.000C . xx	1170 (1200)*
CAP.487.9999 . xx	Ⓢ

ART.	A	B
CAP.487.00RD . xx	140*	93*

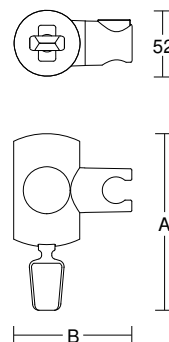
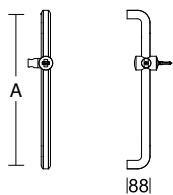

- Sostegno di sicurezza con reggisoffione
- Fixed safety support with shower head holder
- Barre d'appui fixe avec curseur de douche
- Asidero con soporte para ducha regulable en altura



- Reggisoffione girevole con attacco conico universale a scorrimento compatibile con sostegni di sicurezza del PROGRAMMA CAP
- Rotating Shower head holder with universal sliding tapered connection compatible with all safety supports of the PROGRAMMA CAP
- Curseur de douche rabatable avec élément de fixation mobile et conique universel compatible avec les barres d'appui du PROGRAMMA CAP
- Soporte ducha giratorio con base cónica universal deslizable compatible con todos los asideros del PROGRAMA CAP

.XX FINISH

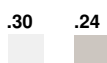



ART.	A
CAP.438.000B . xx . x	1860 (1875)*

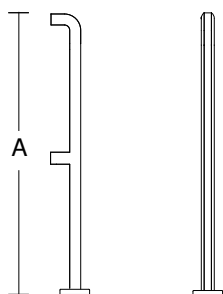

- Sostegno di sicurezza verticale (parete-pavimento) con supporto intermedio
- Vertical safety support (floor-to-wall) with intermediate wall support
- Barre d'appui verticale (mur-sol) avec support intermédiaire
- Asidero vertical (pared-suelo) con soporte intermedio



.XX FINISH

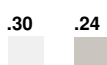

ART.	A
CAP.440.0000 . xx	370 (400)*
CAP.440.000A . xx	570 (600)*
CAP.440.000B . xx	770 (800)*
CAP.440.000C . xx	970 (1000)*
CAP.440.000Z . xx	300 (330)*
CAP.440.9999 . xx	

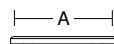

- Sostegno di sicurezza orizzontale
- Horizontal safety support
- Barre d'appui horizontale
- Asidero horizontal



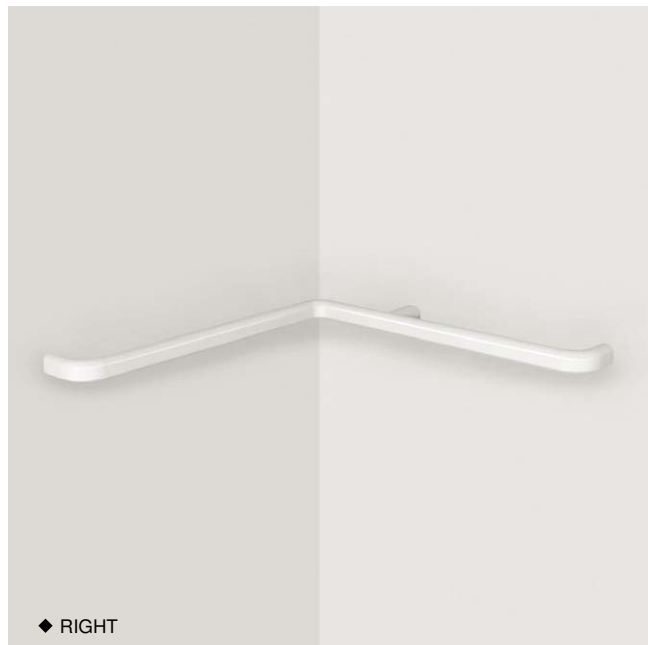

ART.	A
CAP.423.000B . xx	1370 (1400)*
CAP.423.00BL . xx	1570 (1600)*
CAP.423.999B . xx	

ART.	◆	A
CAP.442.0000 . xx . x		760 (776)*
CAP.442.000M . xx . x		960 (976)*
CAP.442.000L . xx . x		1160 (1176)*
CAP.442.9999 . xx . x		

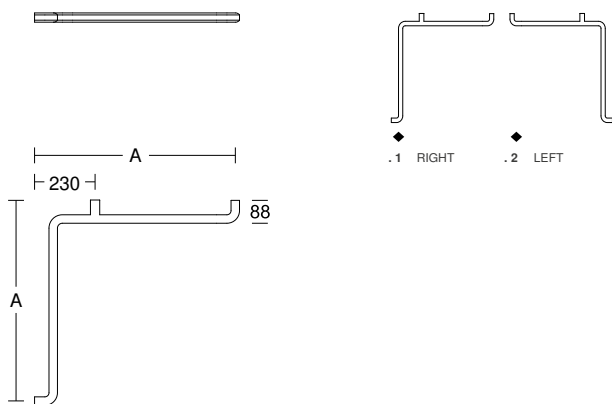
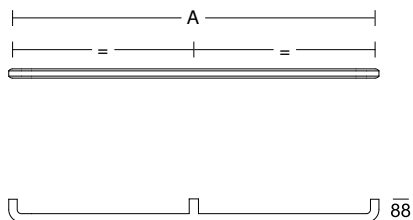

- Sostegno di sicurezza orizzontale con supporto intermedio
- Horizontal safety support with intermediate wall support
- Barre d'appui horizontale avec support intermédiaire
- Asidero horizontal con soporte intermedio



- Sostegno di sicurezza ad angolo simmetrico
- Symmetric corner safety shower rail
- Barre d'appui à coin symétrique
- Asidero en ángulo simétrico



.XX FINISH	.30	.24

- ◆ .1 DESTRO RIGHT DROITE DERECHA
- .2 SINISTRO LEFT GAUCHE IZQUIERDA



◆ LEFT

ART.	◆	A	B
CAP.427.0000 . xx . x		500 (515)*	300 (315)*
CAP.427.9999 . xx . x	Ⓢ	Ⓢ	Ⓢ

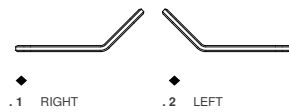
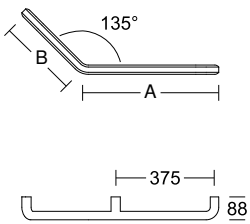

- Sostegno di sicurezza fisso aperto
- Open fixed safety support
- Barre d'appui fixe coudée
- Asidero fijo en ángulo



.XX FINISH	.30	.24



PBA
PATENTED
DESIGN

PATENT
IT 0000101043

ART.	A
CAP.441.000P . xx	600*
CAP.441.00PL . xx	700*
CAP.441.0PLL . xx	850*

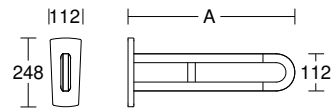

- Sostegno di sicurezza fisso su piastra
- Safety support fixed on plate
- Barre d'appui fixe sur plaque
- Asidero fijo sobre placa



◆	.1 DESTRO RIGHT DROITE DERECHA	.2 SINISTRO LEFT GAUCHE IZQUIERDA

.XX FINISH

.30

.24



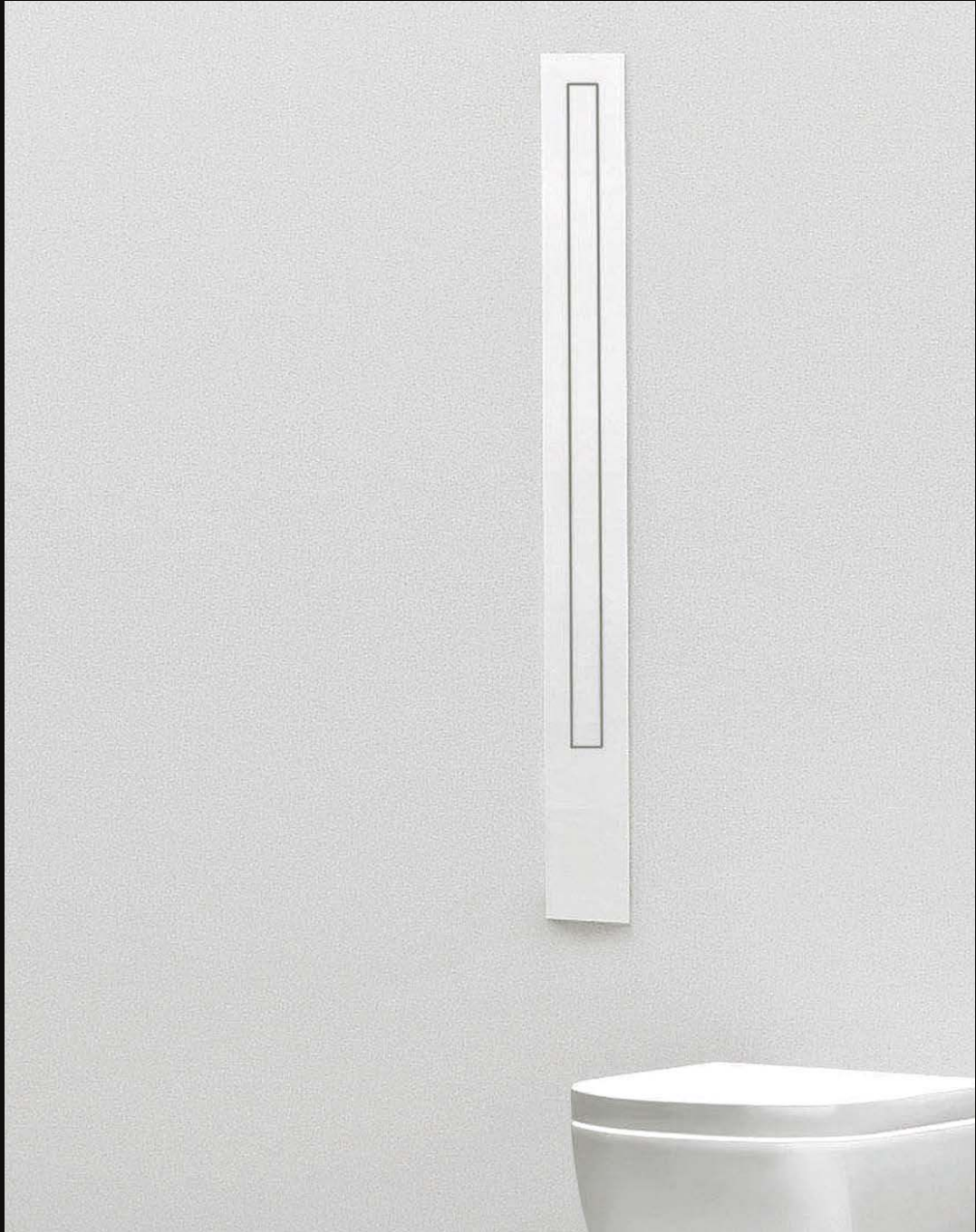



ART.	A	B
CAP.445.000T . xx	600*	852*
CAP.445.0000 . xx	700*	952*

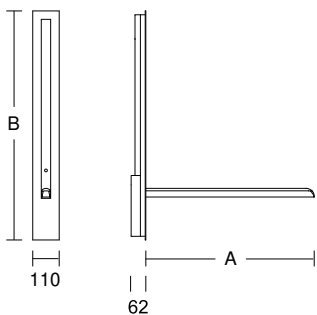

- Sostegno di sicurezza ribaltabile a scomparsa
- Lift-up foldaway safety support
- Barre d'appui relevable escamotable
- Asidero abatible retráctil



ART.	A
4CA.445.000T . xx	600*
4CA.45Y.000T . xx	
4CA.45K.000T . xx	
4CA.445.0000 . xx	700*
4CA.45Y.0000 . xx	
4CA.45K.0000 . xx	
4CA.445.000L . xx	850*
4CA.45Y.000L . xx	
4CA.45K.000L . xx	

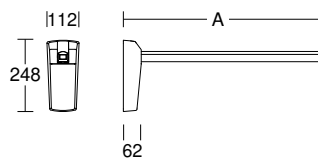

- Sostegno di sicurezza ribaltabile
- Lift-up safety support
- Barre d'appui relevable
- Asidero abatible



.XX FINISH

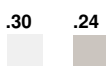





ART.	A	B	C	D
CAP.447.000B .xx	460*	340*	450*	390*

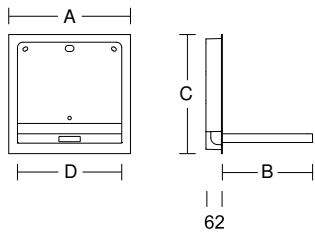

- Seggiolino ribaltabile a scomparsa
- Lift-up foldaway shower seat
- Siège relevable escamotable
- Asiento abatible retráctil





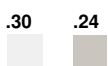

.XX FINISH







ART.	A	
CAP.429.0000 . xx	800*	8
CAP.429.000A . xx	900*	9
CAP.429.000B . xx	1000*	10
CAP.429.000C . xx	1100*	11
CAP.429.000D . xx	1200*	12
CAP.429.000E . xx	1300*	13
CAP.429.9999 . xx		

ART.	A	B	
CAP.436.0000 . xx	800 (815)*	800 (815)*	16
CAP.436.9999 . xx			

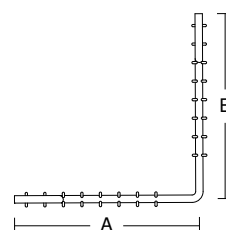
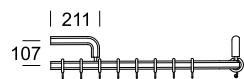
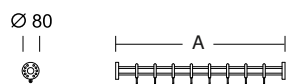





- Reggitenda dritto
- Straight shower curtain rail
- Barre de rideau de douche droit
- Barra de cortina de ducha recta

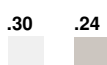



- Reggitenda angolare con due supporti a muro
- Corner shower curtain rail with two wall supports
- Barre de rideau de douche à coin avec deux supports murales
- Barra de cortina de ducha en ángulo con dos soportes en pared

.XX FINISH





ART.	A	B	C	
CAP.436.000B .xx	800 (815)*	800 (815)*	440 (458)*	16
CAP.436.00BA .xx	900 (915)*	900 (915)*	440 (458)*	18
CAP.436.00BB .xx	1000 (1015)*	1000 (1015)*	440 (458)*	20
CAP.436.00BC .xx	1200 (1215)*	1200 (1215)*	440 (458)*	24
CAP.436.00BD .xx	1500 (1515)*	1500 (1515)*	440 (458)*	30
CAP.436.999B .xx				

ART.	A	B	C	
CAP.437.0000 .xx	800 (815)*	800 (830)*	440 (458)*	24
CAP.437.000A .xx	1000 (1015)*	1000 (1030)*	440 (458)*	30
CAP.437.9999 .xx				

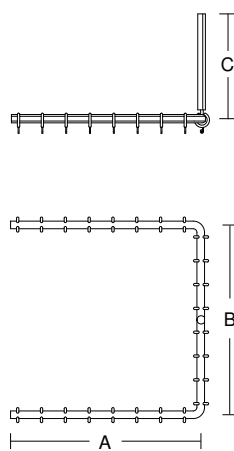
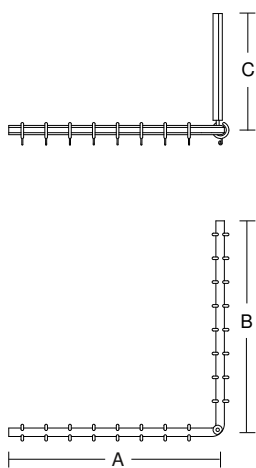

- Reggitenda angolare con supporto a soffitto
- Corner shower curtain rail with ceiling support
- Barre de rideau de douche à coin avec support plafond
- Barra de cortina de ducha en ángulo con soporte de techo

- Reggitenda su tre lati con supporto a soffitto
- Three-sided shower curtain rail with ceiling support
- Barre de rideau de douche sur trois côtés avec support plafond
- Barra de cortina de ducha en "U" con soporte de techo

.XX FINISH

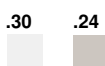



ART.	L	H	
4CN.0SC.000B.01	1200	2000	Art. CAP.429.0000 .xx
			CAP.429.000A .xx
			CAP.429.000B .xx
			CAP.436.0000 .xx*
			CAP.436.000B .xx*
			CAP.436.000BA .xx*
4CN.0SC.000C.01	1800	2000	Art. CAP.429.000C .xx
			CAP.429.000D .xx
			CAP.429.000E .xx
			CAP.436.000BC .xx*
			CAP.436.000BD .xx*
			CAP.437.0000 .xx*

ART.	L	H	
4CN.0SC.00BE.01	1200	2000	Art. CAP.429.0000 .xx
			CAP.429.000A .xx
4CN.0SC.00FE.01	1500	2000	Art. CAP.429.000B .xx
			CAP.429.000C .xx
			CAP.436.00BC .xx*
			CAP.437.0000 .xx*
4CN.0SC.00CE.01	1800	2000	Art. CAP.429.000D .xx
			CAP.429.000E .xx
			CAP.436.00BD .xx*
			CAP.437.000A .xx*
4CN.0SC.00DE.01	2000	2000	Art. CAP.436.0000 .xx
			CAP.436.000B .xx
4CN.0SC.00EE.01	2400	2000	Art. CAP.436.00BA .xx
			CAP.436.00BB .xx

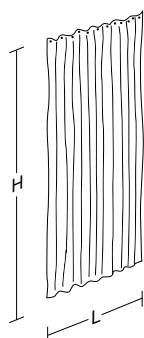

- Tenda ignifuga per doccia
- Fireproof shower curtain
- Rideau de douche ignifuge
- Cortina de ducha ignífuga

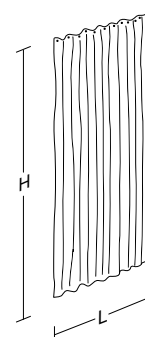

- Tenda impermeabile per doccia
- Waterproof shower curtain
- Rideau de douche imperméable
- Cortina de ducha impermeable



ART.	A	B
CAP.490.0000 .xx	600*	1100*

ART.	A	B	C
CAP.490.00QR .xx	600*	700*	15

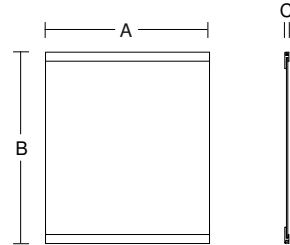
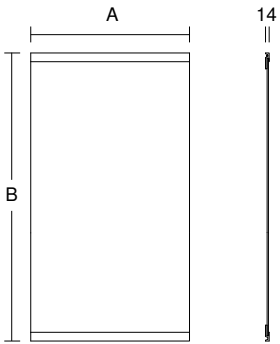

- Specchio fisso
- Fixed mirror
- Miroir fixe
- Espejo fijo

- Specchio fisso con cornice
- Fixed mirror with frame
- Miroir fixe avec cadre
- Espejo fijo con marco

.XX FINISH

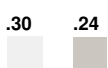



ART.	A	B	C	α
CAP.470.0000 .xx	600*	530*	150*	14°

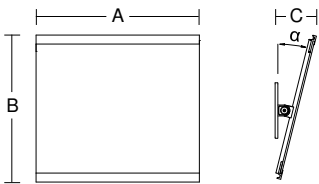

- Specchio orientabile
- Adjustable mirror
- Miroir orientable
- Espejo orientable

.XX FINISH

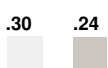



ART.	A	B
CAP.407.0TUA .xx	405*	61*

ART.	A	B
CAP.407.0TUR .xx	405*	75*

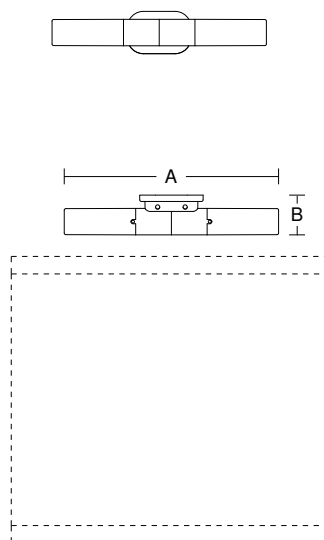
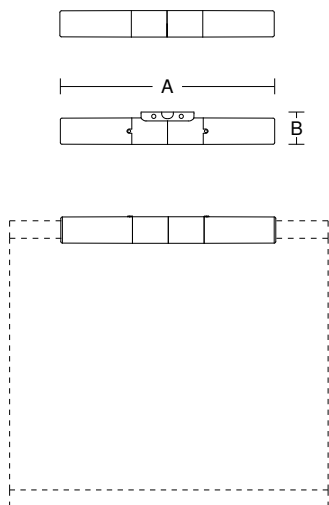

- Lampada da applicare su specchi con cornice.
IP 54 con Art. 4CN.0IP.0068.00
- Lamp for mirrors with frame.
IP 54 with Art. 4CN.0IP.0068.00
- Lampe pour miroirs avec cadre
. IP 54 avec Art. 4CN.0IP.0068.00
- Aplique para espejos con marco
IP 54 con Art. 4CN.0IP.0068.00

CE
IP 54

- Lampada da fissare a parete.
IP 54 con Art. 4CN.0IP.0068.00
- Wall lamp for mirror.
IP 54 with Art. 4CN.0IP.0068.00
- Lampe de mur pour miroir.
IP 54 avec Art. 4CN.0IP.0068.00
- Aplique con fijación en pared
IP 54 con Art. 4CN.0IP.0068.00

CE
IP 54

.XX FINISH

.30	.24



ART.	A	B	C
CAP.483.00PM .xx	150*	110*	44*

ART.	A	B	C
CAP.483.00DM .xx	150*	110*	136*

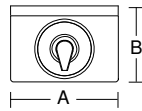
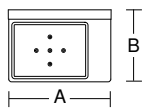
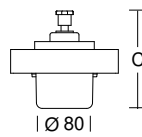
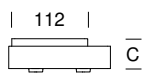

ART.	A	B	C
CAP.483.000P .xx	150*	92*	44*

ART.	A	B	C
CAP.483.000D .xx	150*	92*	136*

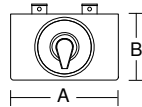
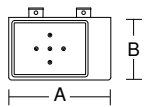
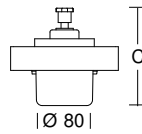
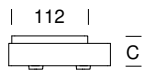

- Mensola con portasapone
- Shelf with soap dish
- Tablette avec porte savon
- Estante con jabonera

- Mensola con dispenser
- Shelf with soap dispenser
- Tablette avec distributeur de savon
- Estante con dispensador de jabón (It 0,4)

.XX FINISH

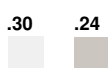



ART. **CAP.483.01BM** . xx A 150* B 110*

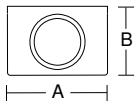
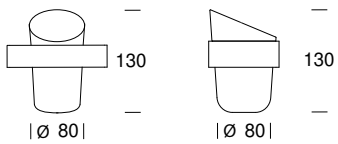

ART. **CAP.483.00IB** . xx A 150* B 92*

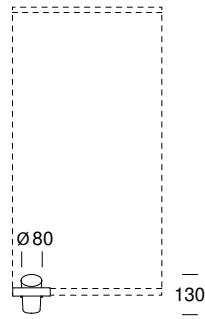
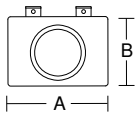
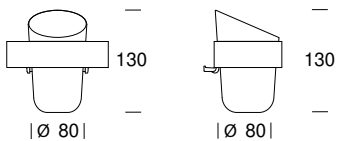

- Mensola con bicchiere conico
- Shelf with conical tumbler
- Tablette avec gobelet conique
- Estante con vaso cónico



ART. **CAP.492.000B** . xx A 210* B 105* C 103*

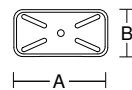

- Mensola applicabile su supporto orizzontale
- Shelf to be integrated to horizontal support
- Tablette accrochable à la barre d'appui horizontale
- Estante aplicable a asidero horizontal

.XX FINISH

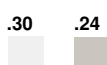



ART.	A	B	C
CAP.004.0000.30	624	40	110

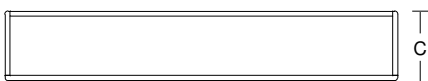
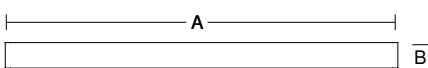

Combinazioni / combinations / combinaisons / combinaciones



CAP.004.0000.30 + CAP.006.0000.30



CAP.004.0000.30 + CAP.005.0000.30



CAP.004.0000.30 + CAP.008.0000.30



CAP.004.0000.30 + CAP.007.0000.30



CAP.004.0000.30

- Mensola per dispenser o bicchiere o vassoio o portasapone / Portasciugamani
- Bathroom shelf for soap dispenser or tumbler or tray or soap dish / towel holder
- Tablette pour doseur savon ou gobelet ou plateau ou porte-savon / porte-serviettes
- Estante para distribuidor o vaso o bandeja o jabonera / Toallero

POWDER-COATED ALUMINIUM

FINISH .30 

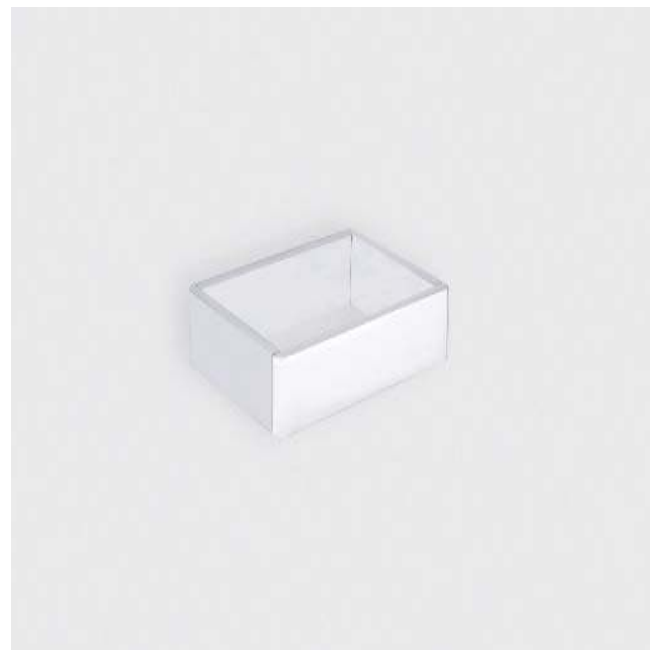

ART.	A	B	C
CAP.003.0000.30	161	40	110

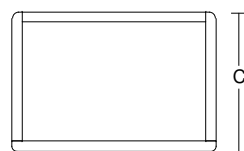
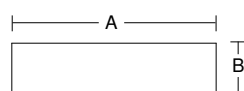

Combinazioni / combinations / combinaisons / combinaciones



CAP.003.0000.30 + CAP.006.0000.30



CAP.003.0000.30 + CAP.005.0000.30



CAP.003.0000.30 + CAP.007.0000.30

- Mensola per dispenser o bicchiere o portasapone
- Bathroom shelf for soap dispenser or tumbler or soap dish
- Tablette pour doseur savon ou gobelet ou porte-savon
- Estante para distribuidor o vaso o jabonera



ART.	A	B	C
CAP.005.0000.30	76	107	105

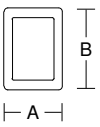
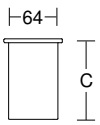

Combinazioni / combinations / combinaisons / combinaciones



CAP.005.0000.30 + CAP.004.0000.30



CAP.005.0000.30 + CAP.003.0000.30

- Bicchiere per mensola
- Tumbler for shelf
- Gobelet pour tablette
- Vaso para estante

CERAMIC
FINISH

.30



ART.	A	B	C
CAP.006.0000.30	76	107	170

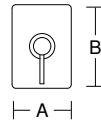
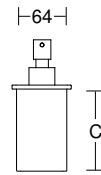

Combinazioni / combinations / combinaisons / combinaciones



CAP.006.0000.30 + CAP.004.0000.30



CAP.006.0000.30 + CAP.003.0000.30

- Dispenser per mensola
- Soap dispenser for shelf
- Doseur savon pour tablette
- Distribuidor jabón para estante



ART.	A	B	C
CAP.007.0000.30	154	107	30

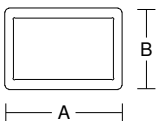
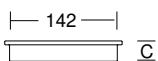

Combinazioni / combinations / combinaisons / combinaciones



CAP.007.0000.30 + CAP.004.0000.30



CAP.007.0000.30 + CAP.003.0000.30

- Portasapone per mensola
- Soap dish for bathroom shelf
- Porte-savon pour tablette
- Jabonera para estante



ART.	A	B	C
CAP.008.0000.30	310	107	12

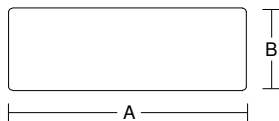
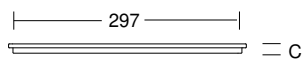

Combinazioni / combinations / combinaisons / combinaciones



CAP.008.0000.30 + CAP.004.0000.30

- Vassoio per mensola
- Tray for bathroom shelf
- Plateau pour tablette
- Bandeja para estante

CERAMIC
FINISH

.30





ART.	A	B
CAP.010.0000.30	193	752

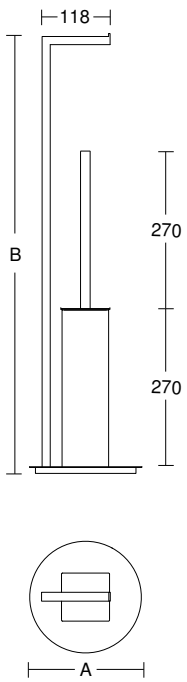

- Piantana porta rotolo e porta scopino
- Toilet paper and brush holder stand
- Support pour porte-papier et ensemble brosse WC
- Soporte de pie portarrollo con escobillero



ART.	A	B	C
CAP.009.0000.30	260	260	325

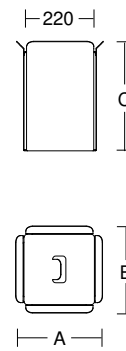

- Cestino
- Paper basket
- Poubelle
- Cubo de basura





ART.	A	B	C
CAP.486.0000 .xx	150*	110*	380*

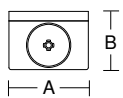
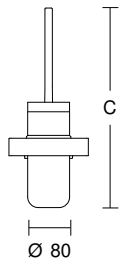

- Portascopino
- Toilet brush set
- Ensemble brosse WC
- Escobillero



ART.	A	B	C
CAP.481.00BA .xx	150*	110	108

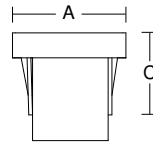

- Portarotolo a muro
- Wall toilet roll holder
- Porte-papier murale
- Portarrotolo de pared

.XX FINISH

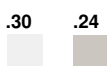



ART.	A	B	C
CAP.498.0000 . 30	120	265*	320*

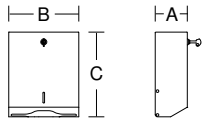

- Portasalviette verniciato bianco Colore ○
- White varnished paper towel dispenser Colour ○
- Distributeur d'essuie-mains papier en Couleur ○
 coloris laqué blanc
- Dispensador de papel toallas pintado blanco Color ○

FINISH .30

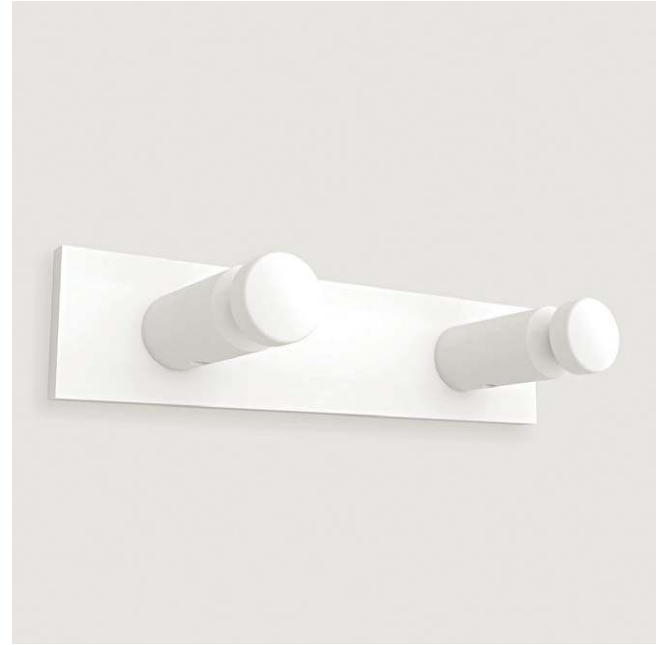
ART.	A	B
CAP.488.0000 . xx	125*	30*

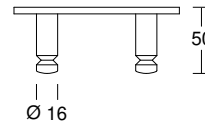
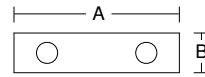

- Gancio appendiabiti doppio
- Double cloth hook
- Patère double
- Percha doble

.XX FINISH .30 .24





ART.	A	B
CAP.562.0000 .xx	Ø 50	76*

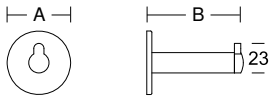

- Appendiabiti fermaporta
- Door-stop cloth hook
- Patère-butoir
- Tope-percha

.XX FINISH

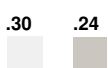

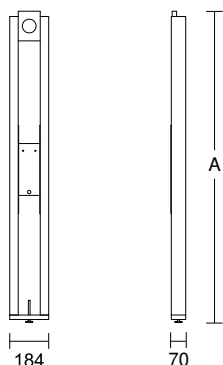

ART.	A	
CAP.445.CG01.00	1470	(I) (F)
CAP.445.CG02.00	1350	(GB)
CAP.445.CG03.00	1410	(D) (A)

- Telaio per applicare art. CAP.445.000T, CAP.445.0000 nelle pareti in **cartongesso**
- Fixture on **plasterboard** walls for the application of articles CAP.445.000T, CAP.445.0000
- Bâti à introduire dans les parois en **placoplâtre** pour l'application des articles CAP.445.000T et CAP.445.0000
- Bastidor que se inserta en las paredes de **cartón yeso** para aplicar los artículos CAP.445.000T, CAP.445.0000

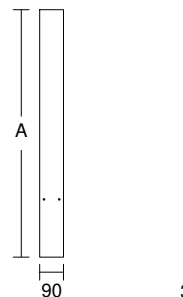

ART.	A
CAP.445.DM0T.00	835
CAP.445.DM00.00	935

- Dima per fori di alloggiamento art. CAP.445.000T (CAP.445.DM0T.00), CAP.445.0000 (CAP.445.DM00.00) nelle pareti in **cartongesso**
- Drill template for art. CAP.445.000T (CAP.445.DM0T.00) and CAP.445.0000 (CAP.445.DM00.00) for **plasterboard** walls
- Gabarit pour trous de fixation des articles CAP.445.000T (CAP.445.DM0T.00) et CAP.445.0000 (CAP.445.DM00.00) pour parois en **placoplâtre**
- Plantilla para orificios de alojamiento del art. CAP.445.000T (CAP.445.DM0T.00) y el CAP.445.0000 (CAP.445.DM00.00) en paredes de **cartón yeso**

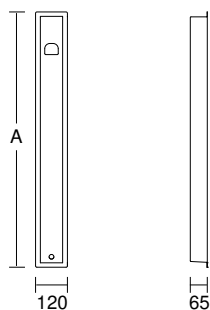

ART.	A
CAP.445.WP0T.00	865
CAP.445.WP00.00	965

- Protezione a tenuta stagna per art CAP.445.000T (CAP.445.WP0T.00), CAP.445.0000 (CAP.445.WP00.00)
- Watertight protection for art CAP.445.000T (CAP.445.WP0T.00), CAP.445.0000 (CAP.445.WP00.00)
- Protection étanche pour les articles CAP.445.000T (CAP.445.WP0T.00), CAP.445.0000 (CAP.445.WP00.00)
- Protección estanca para art CAP.445.000T (CAP.445.WP0T.00), CAP.445.0000 (CAP.445.WP00.00)

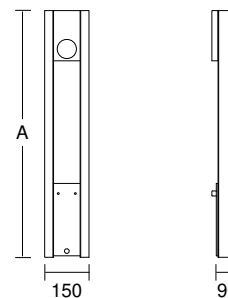

ART.	A
CAP.445.MR0T.00	835
CAP.445.MR00.00	935

- Telaio per applicare art. CAP.445.000T (CAP.445.MR0T.00), CAP.445.0000 (CAP.445.MR00.00) nelle pareti in **muratura**
- Fixture to set in **brick** walls for the application of articles CAP.445.000T (CAP.445.MR0T.00), CAP.445.0000 (CAP.445.MR00.00)
- Bâti à introduire dans les parois **maçonnées** pour l'application des articles CAP.445.000T (CAP.445.MR0T.00), CAP.445.0000 (CAP.445.MR00.00)
- Bastidor que se empotra en las paredes de **mampostería** para aplicar los artículos CAP.445.000T (CAP.445.MR0T.00), CAP.445.0000 (CAP.445.MR00.00)

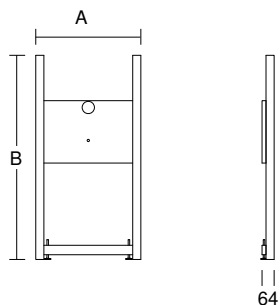

ART.	A	B
CAP.447.CG0B.00	556	1080

- Telaio per applicare art. CAP.447.000B nelle pareti in **cartongesso**
- Fixture on **plasterboard** walls for the application of article CAP.447.000B
- Bâti à introduire dans les parois en **placoplâtre** pour l'application de l'article CAP.447.000B
- Bastidor que se inserta en las paredes de **cartón yeso** para aplicar el artículo CAP.447.000B

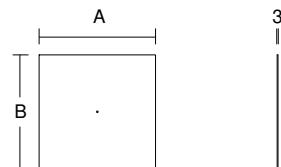

ART.	A	B
CAP.447.DM0B.00	440	430

- Dima per foro di alloggiamento art. CAP.447.000B nelle pareti in **cartongesso**
- Drill template for art. CAP.447.000B for **plasterboard** walls
- Gabarit pour trous de fixation de l'article CAP.447.000B pour parois en **placoplâtre**
- Plantilla para orificios de alojamiento del art. CAP.447.000B en paredes de **cartón yeso**

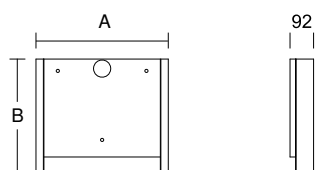

ART.	A	B
CAP.447.MR0B.00	500	430

- Telaio per applicare art. CAP.447.000B nelle pareti in **muratura**
- Fixture to set in **brick** walls for the application of article CAP.447.000B
- Bâti à introduire dans les parois **maçonnées** pour l'application de l'article CAP.447.000B
- Bastidor que se empotra en las paredes de **mampostería** para aplicar el artículo CAP.447.000B

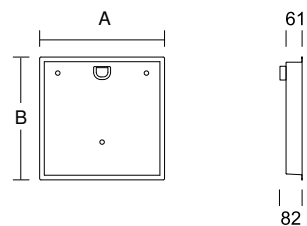

ART.	A	B
CAP.447.WP0B.00	472	465

- Protezione a tenuta stagna per art. CAP.447.000B
- Watertight protection for art. CAP.447.000B
- Protection étanche pour l' article CAP.447.000B
- Protección estanca para art CAP.447.000B

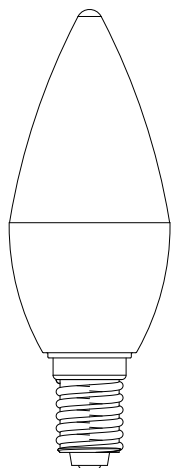

ART.
4CN.407.00LT.00

- Lampadina LED di classe energetica A+
- Light LED bulb energy class A+
- Ampoule LED de classe énergétique A+
- Bombilla LED de eficiencia energética A+

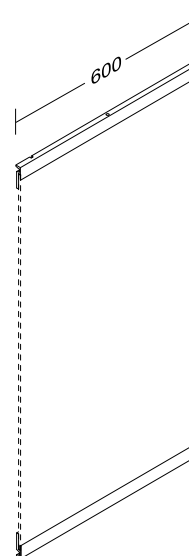

ART.
CAP.4PR.0000 .xx

- Profili reggispecchio
- Mirror profile
- Profils porte-miroir
- Perfiles de sujeción para espejos

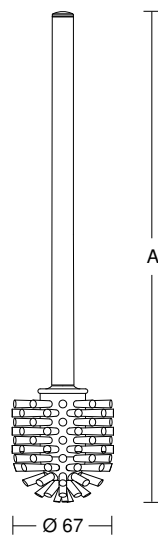

ART. A
4CA.486.00SR .xx 380*

- Scopino di riserva con impugnatura
- Spare toilet brush with handle
- Brosse WC de réserve avec manche
- Escobilla de reserva con mango

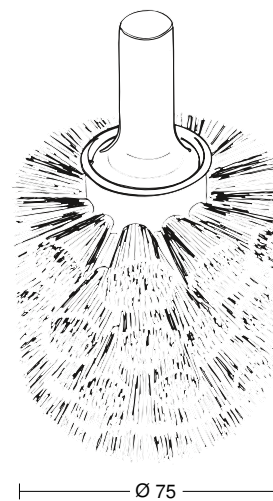

ART.
4CN.486.000B.00

- Scopino di riserva
- Spare toilet brush head
- Tête brosse WC de réserve
- Cabezal de escobilla de reserva para escobillero

.XX FINISH

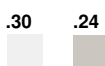

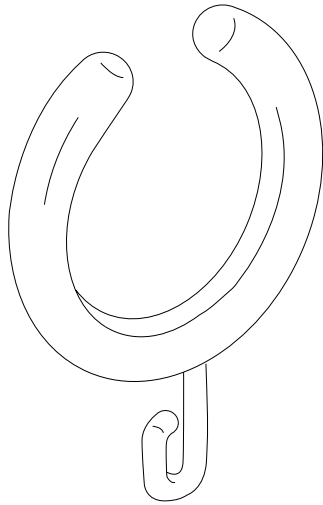

ART.
4CN.0AN.0002 .xx

- Anello reggitenda
- Shower curtain ring
- Anneau pour rideau de douche
- Anillas para cortina

PROGRAMMA PBA WF

PATENT PENDING ITALY 102019000013932
PATENT DEUTCHLAND 202020104488.5

P B A
P A T E N T E D
S Y S T E M

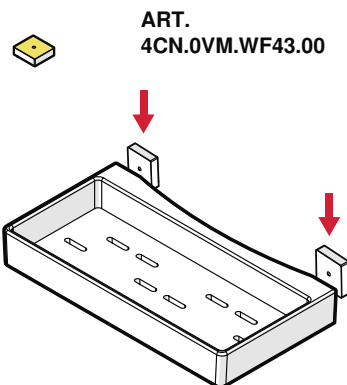

Bathroom shelf 400-NY and CAP

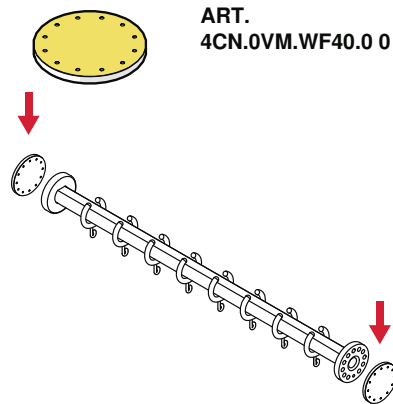

Articles with fixing rose

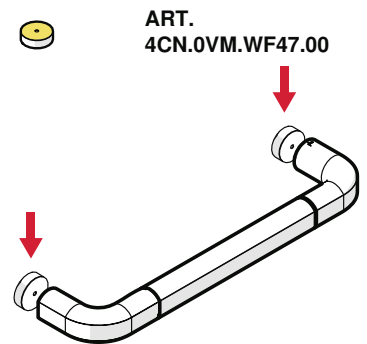

Safety support CAP and ART