

CAP: Ayudas Técnicas Ocultas



ITALIANO
PROGRAMMA CAP

L'eccellente resistenza meccanica dei prodotti del Programma CAP è stata testata e certificata dai nostri laboratori. Tutti gli elementi del Programma sono in alluminio estruso e pressofuso. Trattato con la migliore delle vernici garantisce durata e ottima ritenzione del colore al fine di soddisfare le normative BS6496 e BS6497 e le richieste presenti in tutti i migliori capitolati europei per l'architettura. L'intuizione della realizzazione per moduli, permette soluzioni di assemblaggio in grado di soddisfare qualunque necessità di progetto.

ENGLISH
PROGRAMMA CAP

Tested and certified by PBA laboratories, the CAP Program achieved excellent strength resistance. The CAP Program is produced from extruded and die-cast aluminium components and protected by high quality coatings to guarantee durability and excellent colour fastness, satisfying BS6496 and BS6497 standards together with satisfying all of the foremost European architectural specifications. The modular design concept offers construction applications to meet any needs.

FRANCAIS
PROGRAMMA CAP

L'excellente résistance mécanique des produits du Programme CAP a été testée et certifiée dans nos laboratoires. Tous les éléments du Programme sont réalisés en aluminium extrudé et moulé sous pression. Le traitement avec peinture époxy est exceptionnel, ce qui garantit une durée et une rétention optimale de la couleur conformes aux normes BS6496 et BS6497 et aux caractéristiques requises par tous les cahiers des charges européens les meilleurs en ce qui concerne l'architecture. La conception innovante des modules permet d'obtenir des solutions d'assemblage répondant aux contraintes architecturales.

DEUTSCH
PROGRAMMA CAP

Die Produkte des Programms CAP wurden in unserem Prüflabor getestet und zeichnen sich durch eine hohe mechanische Festigkeit aus. Sie bestehen aus Alu-Druckguss und Strangpressprofilen und sind mit hochfesten Pulverbeschichtungen versehen, die den europäischen Normen BS 6496 und BS 6497 entsprechen. Der modulare Aufbau ermöglicht die Realisierung nahezu jeder architektonischen Anforderung.



ESPAÑOL
PROGRAMMA CAP

La excelente resistencia mecánica de los productos del Programa CAP ha sido ensayada y certificada por nuestros laboratorios. Todos los elementos que componen el Programa son de aluminio extrusionado y moldeado a presión. El tratamiento con las mejores pinturas garantiza la duración y una excelente retención del color, a fin de satisfacer las normativas BS6496 y BS6497 y los requisitos de los mejores pliegos de condiciones europeos para la arquitectura. La intuición de la realización modular permite crear soluciones de montaje que satisfacen las necesidades de todo tipo de proyectos.

NEDERLANDS
PROGRAMMA CAP

De uitstekende mechanische weerstand van de producten van het Programma CAP werd getest en geattesteerd door onze laboratoria. Alle elementen van het Programma zijn gemaakt in geëxtrudeerd en gegoten aluminium. Ze worden behandeld met de beste lakken en garanderen duurzaamheid en een optimaal behoud van de kleur, zodat wordt voldaan aan de normenstelsels BS6496 en BS6497 en de noodzaak van de beste Europese bestekken en voorwaarden voor de architectuur. Door de intentie van de realisatie in modules zijn montageoplossingen mogelijk die aan eender welk ontwerp kunnen voldoen.

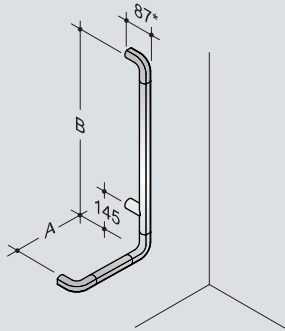

PROGRAMMA CAP
R

Sostegno di sicurezza a "L"
 "L" safety support
 Barre d'appui forme a "L"
 Sicherheitsgriff L-form
 Ayudas técnicas asidero en "L"
 L-vormige veiligheidssteun

ART.	A	B
CAP.422.0000. ..	220 (252)*	520 (552)*
CAP.422.000M. ..	300 (332)*	520 (552)*
CAP.422.000L. ..	320 (352)*	720 (752)*
CAP.422.00LA. ..	400 (432)*	1160 (1192)*

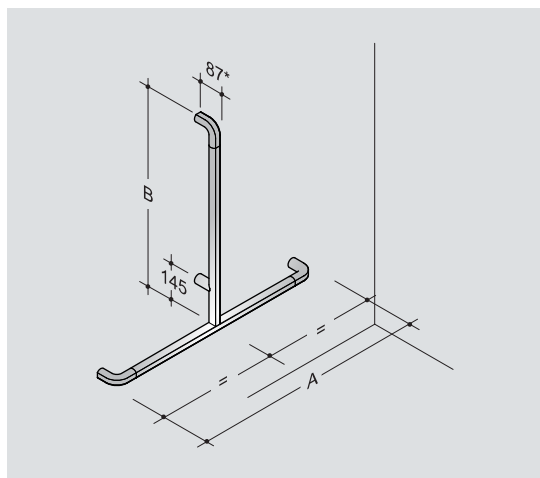

Sostegno di sicurezza a "T"
 T-sharped safety support
 Barre d'appui forme a "T"
 Sicherheitsgriff T-Form
 Asidero vertical en "T"
 T-veiligheidssteun

ART.	A	B
CAP.433.0000. ..	1570 (1600)*	820 (852)*

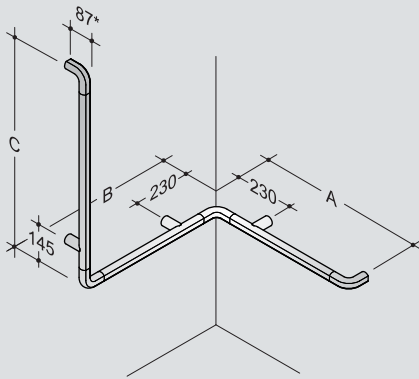
L

Sostegno di sicurezza a angolo e elemento verticale
 Corner shower rail with shower head rail
 Main courante de maintien avec barre de douche
 Duschhandlauf mit Brausehalterstange
 Asidero en ángulo con empuñadura vertical
 Hoekveiligheidssteun met vertikale steun

ART.	A	B	C
CAP.424.0000. ..	660 (675)*	660 (678)*	820 (852)*
CAP.424.000L. ..	760 (775)*	400 (418)*	1160 (1192)*
CAP.424.00LA. ..	760 (775)*	760 (778)*	1160 (1192)*

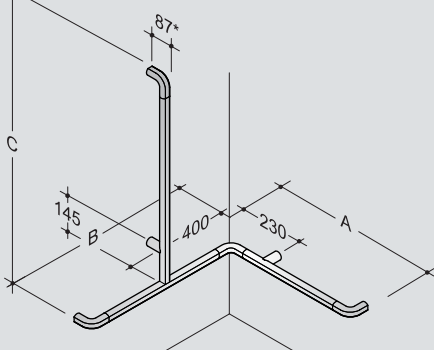
L

Sostegno di sicurezza a angolo e elemento verticale
 Corner shower rail with shower head rail
 Main courante de maintien avec barre de douche
 Duschhandlauf mit Brausehalterstange
 Asidero en ángulo con empuñadura vertical
 Hoekveiligheidssteun met vertikale steun

ART.	A	B	C
CAP.443.000B. ..	760 (775)*	760 (775)*	1160 (1192)*
CAP.443.00BL. ..	760 (775)*	1185 (1200)*	1160 (1192)*

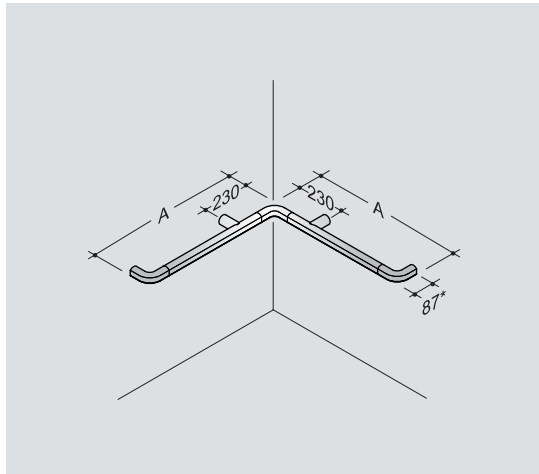
PROGRAMMA CAP

Sostegno di sicurezza a angolo
 Corner safety shower rail
 Main courante de maintien
 Handlauf für Duschecke
 Asidero en ángulo
 Hoekveiligheidssteun

ART.	A
CAP.442.0000. ..	760 (775)*
CAP.442.000M. ..	960 (975)*
CAP.442.000L. ..	1160 (1175)*

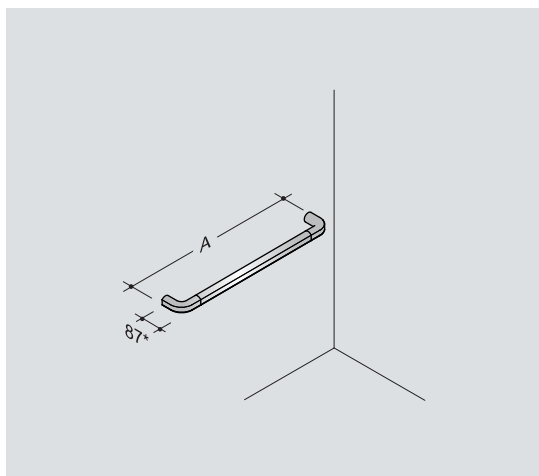

Sostegno di sicurezza orizzontale
 Horizontal safety support
 Barre d'appui horizontale
 Horizontaler Haltegriff
 Asidero horizontal
 Horizontale veiligheidssteun

ART.	A
CAP.440.0000. ..	370 (400)*
CAP.440.000A. ..	570 (600)*
CAP.440.000B. ..	770 (800)*
CAP.440.000C. ..	970 (1000)*
CAP.440.000Z. ..	300 (330)*

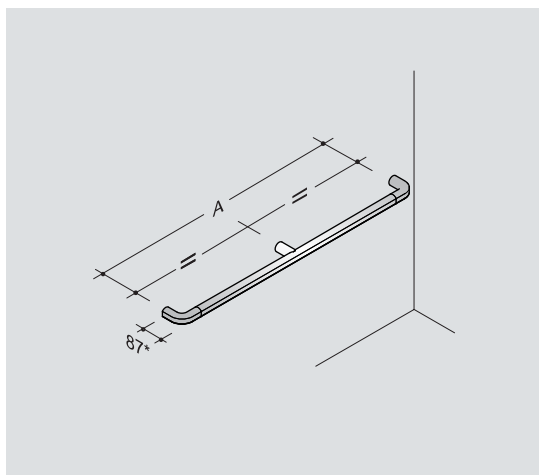

Sostegno di sicurezza orizzontale con supporto intermedio
 Horizontal grab rail with intermediate wall support
 Barre d'appui horizontale avec support intermediaire
 Haltegriff, horizontal mit gerader Mittelstütze
 Asidero horizontal con soporte intermedio
 Horizontale veiligheidssteun met tussensteun

ART.	A
CAP.423.000B. ..	1370 (1400)*
CAP.423.00BL. ..	1570 (1600)*

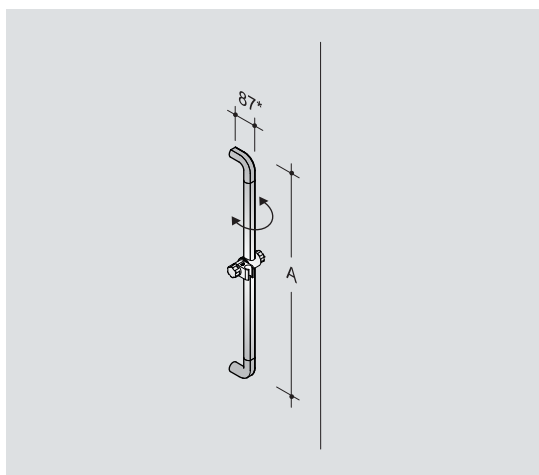

Sostegno di sicurezza con reggisoffione
 Fixed safety support with shower head holder
 Barre d'appui fixe avec curseur de douche
 Haltegriff mit Brausehalter
 Asidero con soporte regulable en altura para ducha
 Veiligheidssteun met douchekophouder

ART.	A
CAP.487.0000. ..	570 (600)*
CAP.487.000A. ..	770 (800)*
CAP.487.000B. ..	970 (1000)*
CAP.487.000C. ..	1170 (1200)*

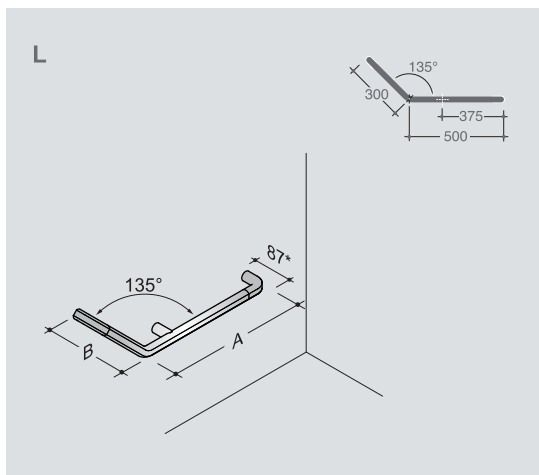
PROGRAMMA CAP

Sostegno di sicurezza fisso aperto
 Fixed open safety support
 Barre d'appui fixe ouverte
 Handlauf für Wanne
 Asidero fijo abierto
 Vaste open veiligheidssteun

ART.	A	B
CAP.427.0000. ..	500 (515)*	300 (315)*

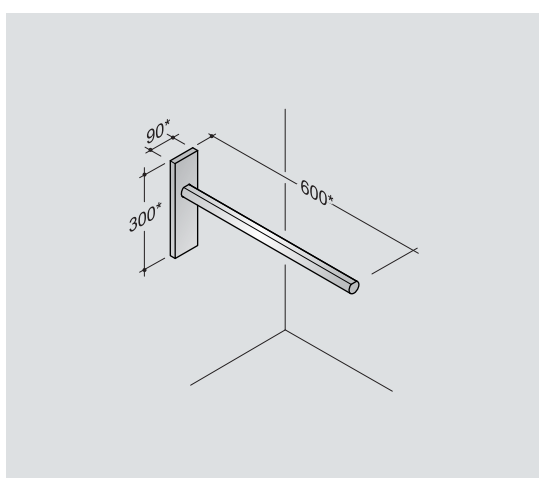

Sostegno di sicurezza fisso su piastra
 Safety support fixed on plate
 Barre d'appui fixe sur plaque
 Feststehender Wandstützgriff auf Wandplatte
 Asidero fijo montado sobre placa
 Vaste veiligheidssteun op plaat

ART.
CAP.441.000P. ..

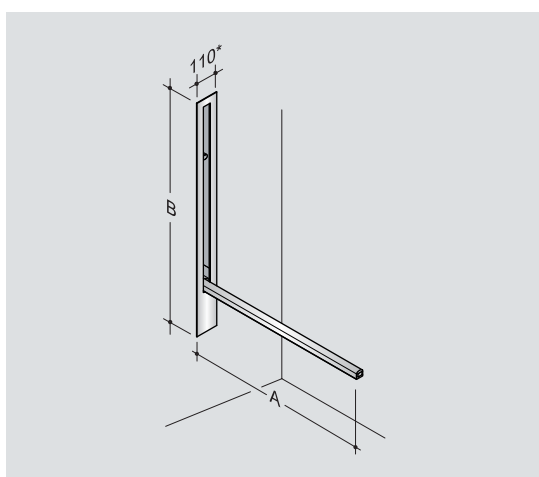

Sostegno di sicurezza ribaltabile a scomparsa
 Lift-up foldaway safety support
 Barre d'appui relevable escamotable
 Stützklappgriff versenkbar
 Asidero de seguridad abatible oculto
 Geïntegreerde opklapbare veiligheidssteun

ART.	A	B
CAP.445.000T. ..	600*	852*
CAP.445.0000. ..	700*	952*

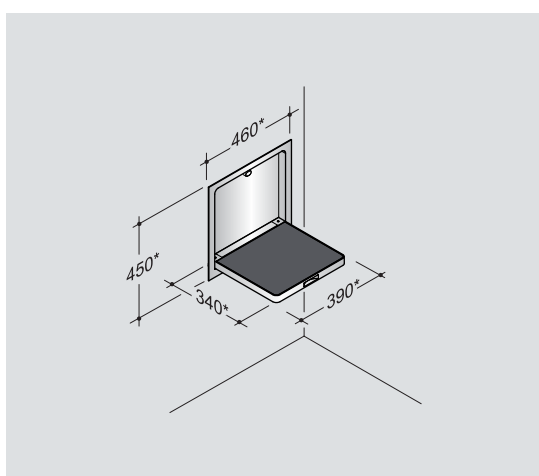
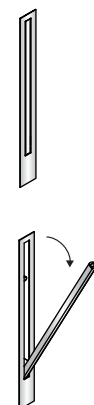

Seggiolino ribaltabile a scomparsa
 Lift-up foldaway shower seat
 Siege relevable escamotable
 Duschsitz, klappbar versenkbar
 Asiento abatible oculto
 Geïntegreerde opklapbare zit

ART.
CAP.447.000B. ..

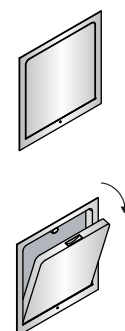

PROGRAMMA CAP

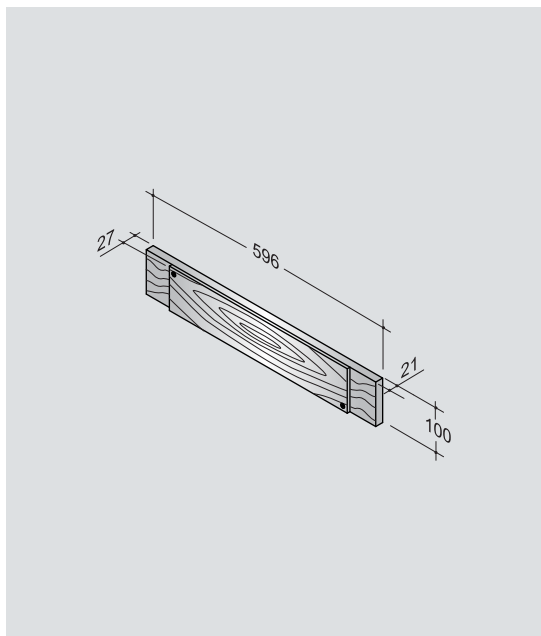

PROGRAMMA CAP

Elemento per applicare gli ausili fissi nelle pareti in cartongesso.
 Component for the application of grab rails to plasterboard walls.
 Structure à intégrer dans les parois en placoplâtre pour l'application des barres d'appui fixes.
 Montagelemente.
 Elemento que se inserta en las paredes de cartón yeso para aplicar las ayudas técnicas fijas.
 Element dat in gipsplaten wanden moet geplaatst worden om de vaste componenten te bevestigen.

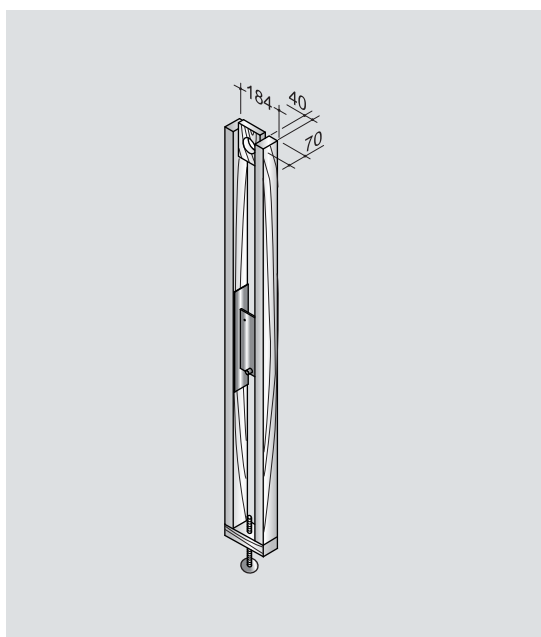
ART.
CAP.400.CG01.00

Telaio per applicare art. CAP.445.000T, CAP.445.0000 nelle pareti in cartongesso.
 Fixture on plasterboard walls for the application of articles CAP.445.000T, CAP.445.0000.
 Bâti à introduire dans les parois en placoplâtre pour l'application des articles CAP.445.000T et CAP.445.0000.
 Einbaurahmen zur Montage der Artikel CAP.445.000T und CAP.445.0000 in Gipskartonwände.
 Bastidor que se inserta en las paredes de cartón yeso para aplicar los artículos CAP.445.000T, CAP.445.0000.
 Frame dat in gipsplaten wanden moet geplaatst worden om de artikels CAP.445.000T, CAP.445.0000 te bevestigen.

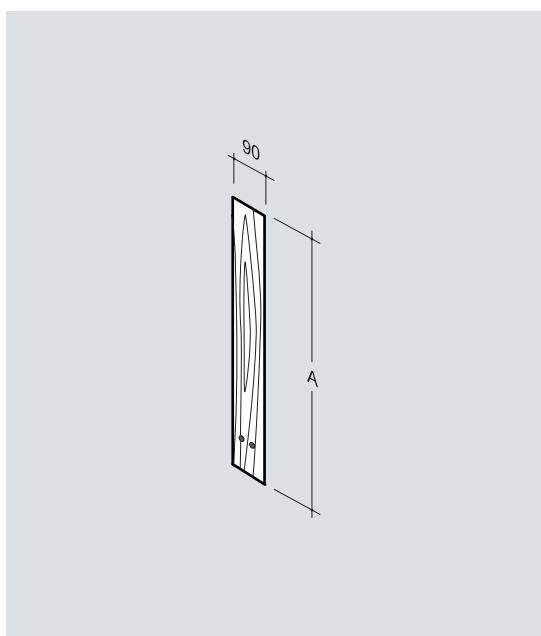
ART.
CAP.445.CG01.00

Dima per fori di alloggiamento art. CAP.445.000T (CAP.445.DM0T.00), CAP.445.0000 (CAP.445.DM00.00) nelle pareti in cartongesso.
 Drill template for art. CAP.445.000T (CAP.445.DM0T.00) and CAP.445.0000 (CAP.445.DM00.00) for plasterboard walls.
 Gabarit pour trous de fixation des articles CAP.445.000T (CAP.445.DM0T.00) et CAP.445.0000 (CAP.445.DM00.00) pour parois en placoplâtre.
 Bohrschablone zur Befestigung der Artikel CAP.445.000T (CAP.445.DM0T.00) und CAP.445.0000 (CAP.445.DM00.00) an Gipskartonwänden.
 Plantilla para orificios de alojamiento del art. CAP.445.000T (CAP.445.DM0T.00) y el CAP.445.0000 (CAP.445.DM00.00) en paredes de cartón yeso.
 Mal voor het boren van de gaten art. CAP.445.000T (CAP.445.DM0T.00), en CAP.445.0000 (CAP.445.DM00.00) voor wanden in gipsplaat.

ART.
A
CAP.445.DM0T.00 835
CAP.445.DM00.00 935

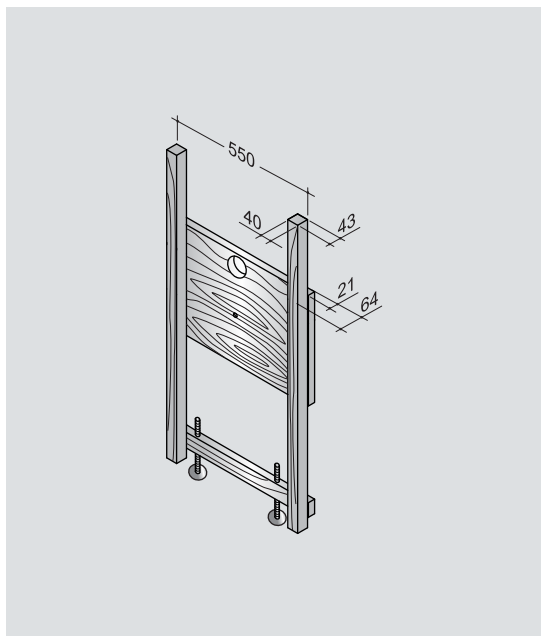

Telaio per applicare art. CAP.447.000B nelle pareti in cartongesso.
 Fixture on plasterboard walls for the application of article CAP.447.000B.
 Bâti à introduire dans les parois en placoplâtre pour l'application de l'article CAP.447.000B.
 Einbaurahmen zur Montage des Artikels CAP.447.000B in Gipskartonwände.
 Bastidor que se inserta en las paredes de cartón yeso para aplicar el artículo CAP.447.000B.
 Frame dat in gipsplaten wanden moet geplaatst worden om het artikel CAP.447.000B te bevestigen.

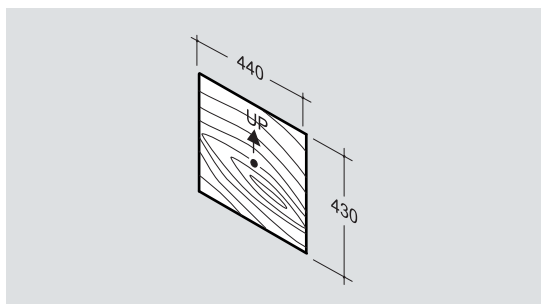
ART.
CAP.447.CG0B.00

Dima per foro di alloggiamento art. CAP.447.000B nelle pareti in cartongesso.
 Drill template for art. CAP.447.000B for plasterboard walls.
 Gabarit pour trous de fixation de l'article CAP.447.000B pour parois en placoplâtre.
 Bohrschablone zur Befestigung des Artikels CAP.447.000B an Gipskartonwänden.
 Plantilla para orificio de alojamiento del art. CAP.447.000B en paredes de cartón yeso.
 Mal voor het boren van het gat art. CAP.447.000B voor wanden in gipsplaat.

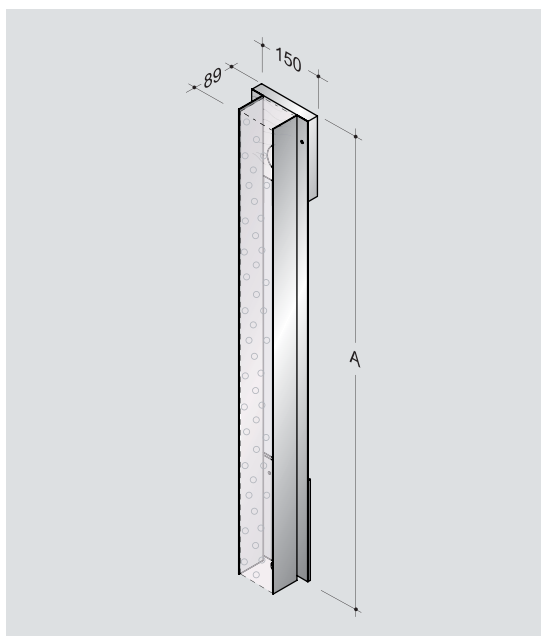
ART.
CAP.447.DM0B.00

Telaio per applicare art. CAP.445.000T (CAP.445.MR0T.00), CAP.445.0000 (CAP.445.MR00.00) nelle pareti in muratura.
 Fixture to set in brick walls for the application of articles CAP.445.000T (CAP.445.MR0T.00), CAP.445.0000 (CAP.445.MR00.00).
 Bâti à introduire dans les parois maçonnées pour l'application des articles CAP.445.000T (CAP.445.MR0T.00), CAP.445.0000 (CAP.445.MR00.00).
 Einbaurahmen zur Montage der Artikel CAP 445.000T (CAP.445.MR0T.00) und CAP 445.0000 (CAP.445.MR00.00) in Mauerwerk.
 Bastidor que se empotra en las paredes de mampostería para aplicar los artículos CAP.445.000T (CAP.445.MR0T.00), CAP.445.0000 (CAP.445.MR00.00).
 Frame dat in gemetselde wanden moet gemetseld worden om de artikels CAP.445.000T (CAP.445.MR0T.00), CAP.445.0000 (CAP.445.MR00.00) te bevestigen.

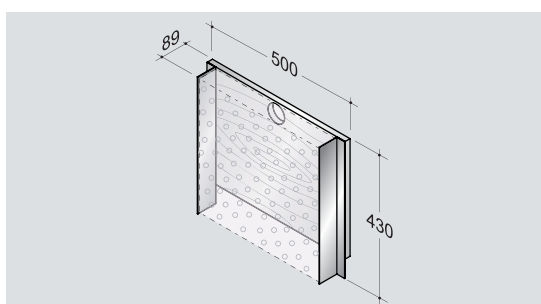
ART.
A
CAP.445.MR0T.00 835
CAP.445.MR00.00 935

Telaio per applicare art. CAP.447.000B nelle pareti in muratura.
 Fixture to set in brick walls for the application of article CAP.447.000B.
 Bâti à introduire dans les parois maçonnées pour l'application de l'article CAP.447.000B.
 Einbaurahmen zur Montage des Artikels CAP.447.000B in Mauerwerk.
 Bastidor que se empotra en las paredes de mampostería para aplicar el artículo CAP.447.000B.
 Frame dat in gemetselde wanden moet gemetseld worden om het artikel CAP.447.000B te bevestigen.

ART.
CAP.447.MR0B.00

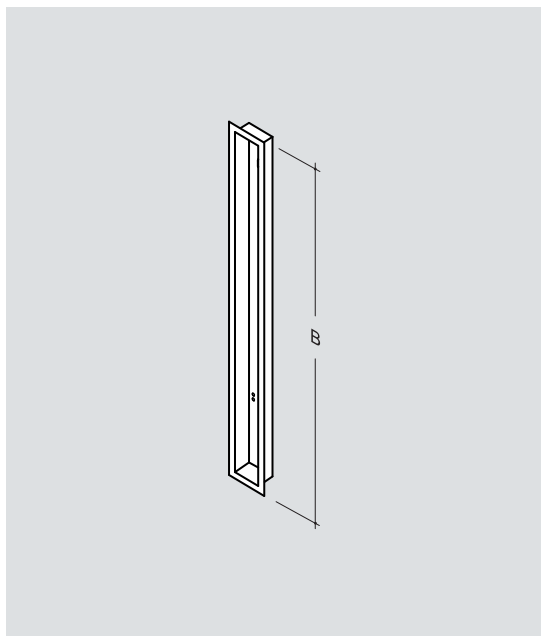
PROGRAMMA CAP

Protezione a tenuta stagna per art CAP.445.000T (CAP.445.WP0T.00), CAP.445.0000 (CAP.445.WP00.00).

Watertight protection for art CAP.445.000T (CAP.445.WP0T.00), CAP.445.0000 (CAP.445.WP00.00).

Protection étanche pour les articles CAP.445.000T (CAP.445.WP0T.00), CAP.445.0000 (CAP.445.WP00.00).

Schutz gegen Feuchtigkeit der Artikels CAP.445.000T (CAP.445.WP0T.00) und CAP.445.0000 (CAP.445.WP00.00).

Protección estanca para art. CAP.445.000T (CAP.445.WP0T.00), CAP.445.0000 (CAP.445.WP00.00).

Waterdichte muurbescherming voor artikels CAP.445.000T (CAP.445.WP0T.00), CAP.445.0000 (CAP.445.WP00.00).

ART.	B
CAP.445.WP0T.00	865
CAP.445.WP00.00	965

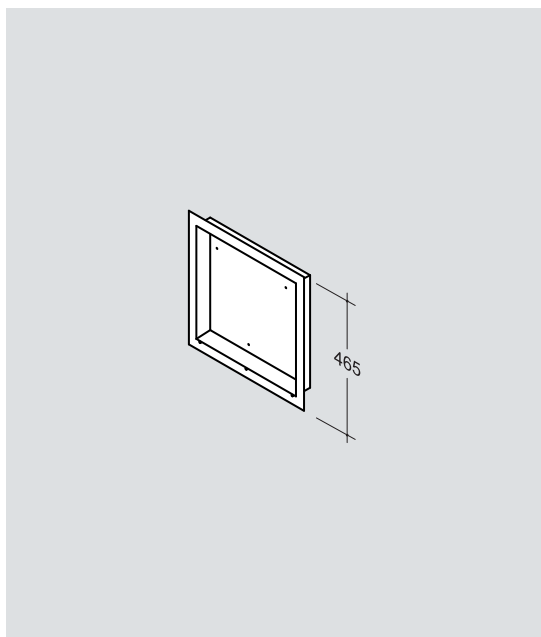

Protezione a tenuta stagna per art. CAP.447.000B

Watertight protection for art. CAP.447.000B

Protection étanche pour l' article CAP.447.000B

Schutz gegen Feuchtigkeit des Artikels CAP.447.000B

Protección estanca para art. CAP.447.000B

Waterdichte muurbescherming voor artikel CAP.447.000B

ART.
CAP.447.WP0B.00

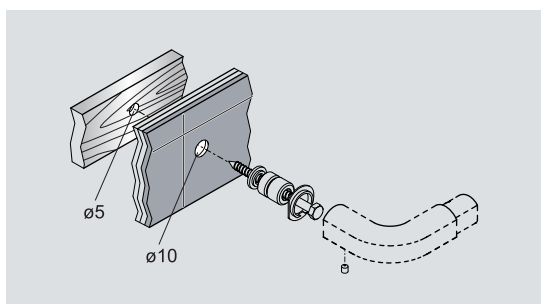

Dotazione per applicare gli ausili fissi sulle pareti in cartongesso.

Kit for the application of grab rails on plasterboard walls.

Éléments fournis pour l'application sur les parois en placoplâtre des barres d'appui fixes.

Befestigungssätze zur Montage an Gipskartonwänden.

Equipamiento para aplicar ayudas técnicas fijas en paredes de cartón yeso.

Bevestigingsset voor de vaste componenten op gipsplaten wanden te bevestigen.

ART.
CAP.0VM.CG01.00

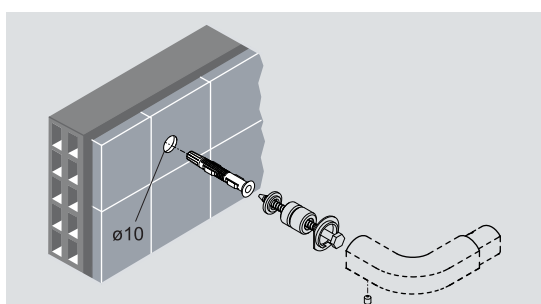

Dotazione per applicare gli ausili fissi sulle pareti in muratura.

Kit for the application of grab rails on brick walls.

Éléments fournis pour l'application sur les parois maçonnées des barres d'appui fixes.

Befestigungssätze zur Montage an Massivwänden.

Equipamiento para aplicar ayudas técnicas fijas en paredes de mampostería.

Bevestigingsset voor de vaste componenten op gemetselde wanden te bevestigen.

ART.
CAP.0VM.MR01.00

PROGRAMMA CAP

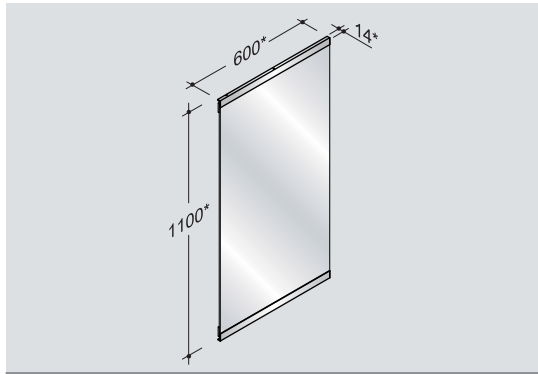

PROGRAMMA CAP

Specchio fisso
Fixed mirror
Miroir fixe
Wandspiegel
Espejo fijo
Vaste spiegel

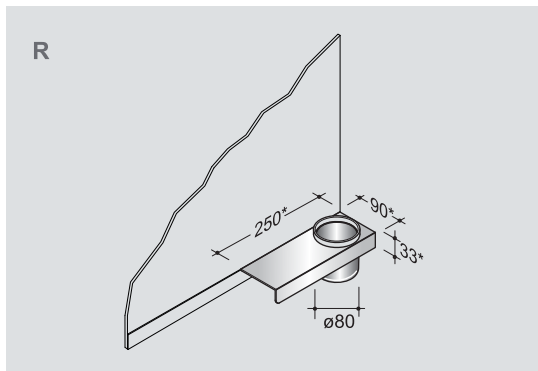
ART.
CAP.490.0000. ..

Mensola con bicchiere
Bathroom shelf with tumbler
Tablette avec gobelet
Ablage mit Becher
Estante con portavasos
Tablethouder met bekerhouder

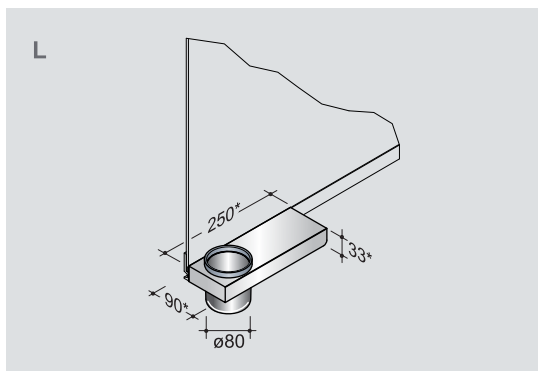
ART.
CAP.483.00BR. ..

Mensola con bicchiere
Bathroom shelf with tumbler
Tablette avec gobelet
Ablage mit Becher
Estante con portavasos
Tablethouder met bekerhouder

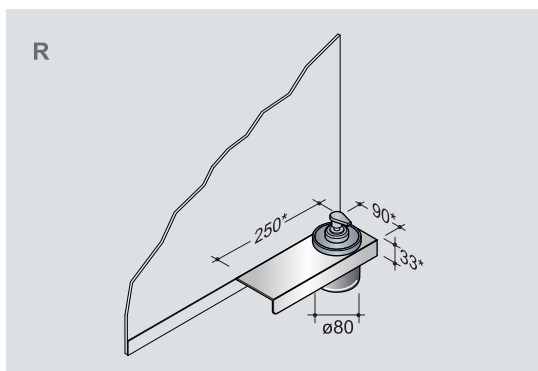
ART.
CAP.483.00BL. ..

Mensola con dispenser
Bathroom shelf with soap dispenser
Tablette avec doseur savon
Ablage mit Seifenspender
Estante con dispensador de jabón
Tablethouder met zeepverdeler

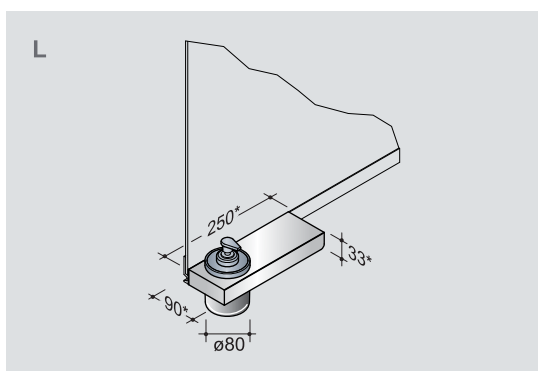
ART.
CAP.483.00DR. ..

Mensola con dispenser
Bathroom shelf with soap dispenser
Tablette avec doseur savon
Ablage mit Seifenspender
Estante con dispensador de jabón
Tablethouder met zeepverdeler

ART.
CAP.483.00DL. ..

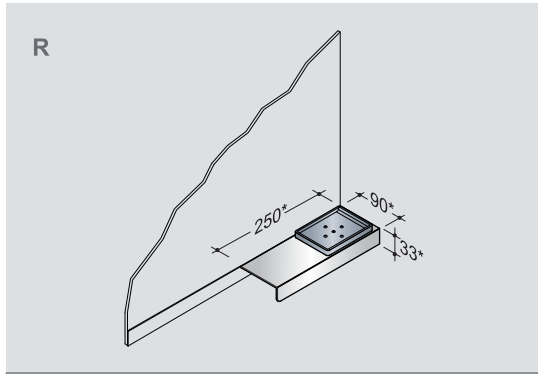
PROGRAMMA CAP

Mensola con portasapone
 Bathroom shelf with soap dish
 Tablette avec porte savon
 Ablage mit Seifenschale
 Estante con jabonera
 Tablethouder met zeephouder

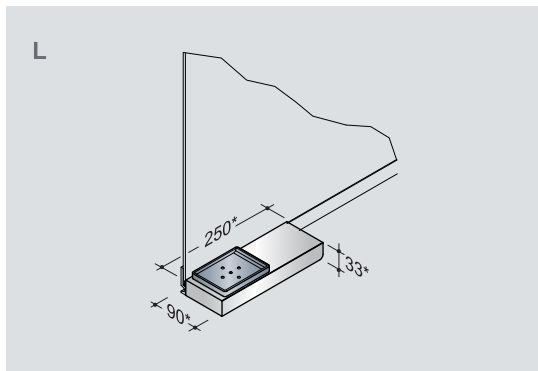
ART.
CAP.483.00PR. ..

Mensola con portasapone
 Bathroom shelf with soap dish
 Tablette avec porte savon
 Ablage mit Seifenschale
 Estante con jabonera
 Tablethouder met zeephouder

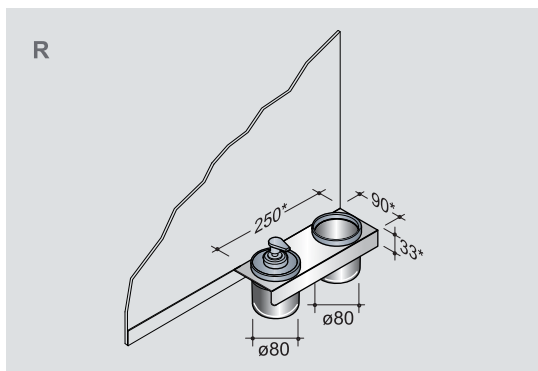
ART.
CAP.483.00PL. ..

Mensola con bicchiere e dispenser
 Bathroom shelf with tumbler and soap dispenser
 Tablette avec gobelet et doseur savon
 Ablage mit Becher ünd Seifenspender
 Estante con portavasos y dispensador de jabón
 Tablethouder met bekerhouder en zeepverdeler

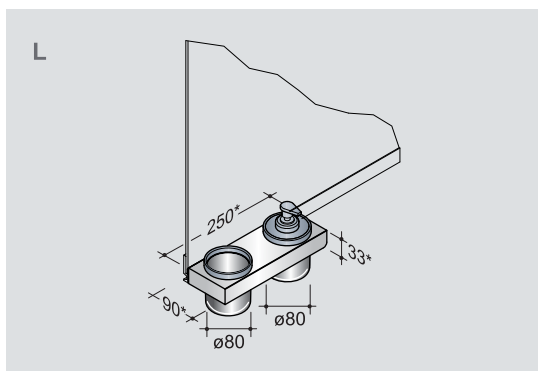
ART.
CAP.483.0BDR. ..

Mensola con bicchiere e dispenser
 Bathroom shelf with tumbler and soap dispenser
 Tablette avec gobelet et doseur savon
 Ablage mit Becher ünd Seifenspender
 Estante con portavasos y dispensador de jabón
 Tablethouder met bekerhouder en zeepverdeler

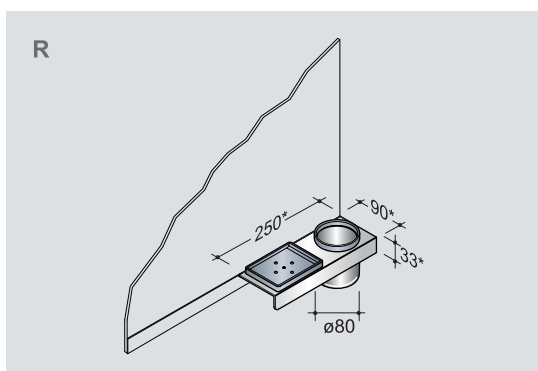
ART.
CAP.483.0BDL. ..

Mensola con bicchiere e portasapone
 Bathroom shelf with tumbler and soap dish
 Tablette avec gobelet et porte savon
 Ablage mit Becher ünd Seifenschale
 Estante con portavasos y jabonera
 Tablethouder met bekerhouder en zeephouder

ART.
CAP.483.0BPR. ..

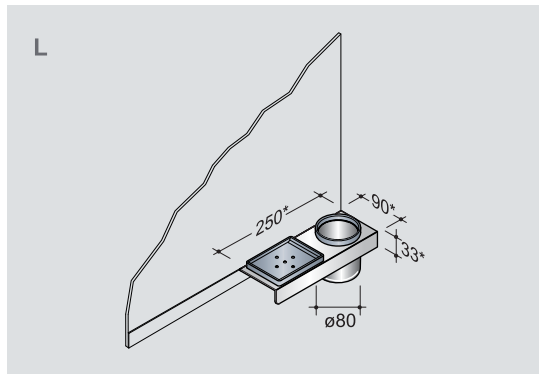
PROGRAMMA CAP

Mensola con bicchiere e portasapone
 Bathroom shelf with tumbler and soap dish
 Tablette avec gobelet et porte savon
 Ablage mit Becher und Seifenschale
 Estante con portavasos y jabonera
 Tablethouder met bekerhouder en zeephouder

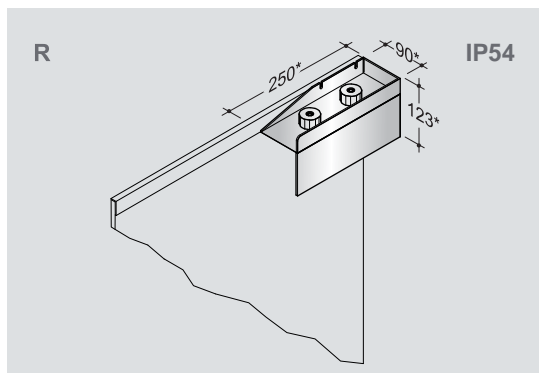
ART.
CAP.483.0BPL. ..

Lampada
 Lamp
 Lampe
 Leuchte
 Applique
 Lamp

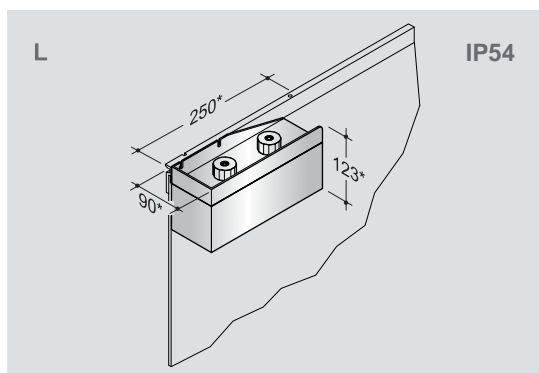
ART.
CAP.407.000R. ..

Lampada
 Lamp
 Lampe
 Leuchte
 Applique
 Lamp

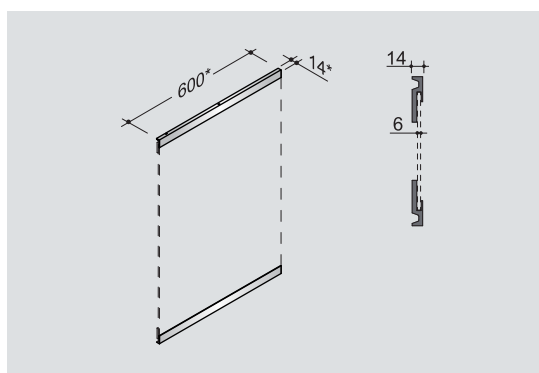
ART.
CAP.407.000L. ..

Profili reggispecchio
 Mirror profile
 Profils porte-miroir
 Spiegelhalter
 Perfiles de sujeción para espejos
 Spiegelprofilen

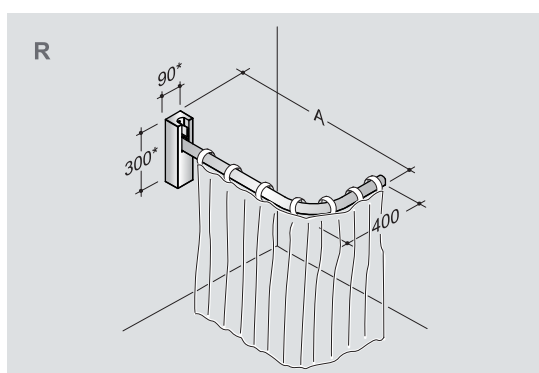
ART.
CAP.4PR.0000. ..

Reggitenda basso ribaltabile
 Lift-up support with shower curtain
 Barre relevable avec rideau de douche
 Duschspritzschutz klappbar
 Barra de cortina baja abatible con cortina
 Opklapbare lage douchegordijnhouder

ART.
A
CAP.435.000R. .. 800
CAP.435.000L. .. 800

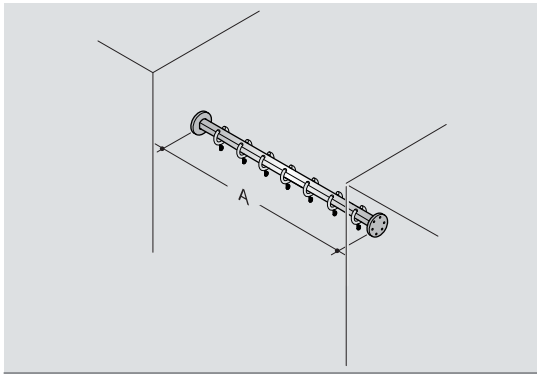
PROGRAMMA CAP

Reggitenda dritto
Shower curtain rail
Barre de rideau de douche
Duschvorhangstange gerade
Barra de cortina recta
Rechte douchegordijnhouder

ART.	A	n°
CAP.429.0000. ..	800	8
CAP.429.000A. ..	900	9
CAP.429.000B. ..	1000	10
CAP.429.000C. ..	1100	11
CAP.429.000D. ..	1200	12
CAP.429.000E. ..	1300	13

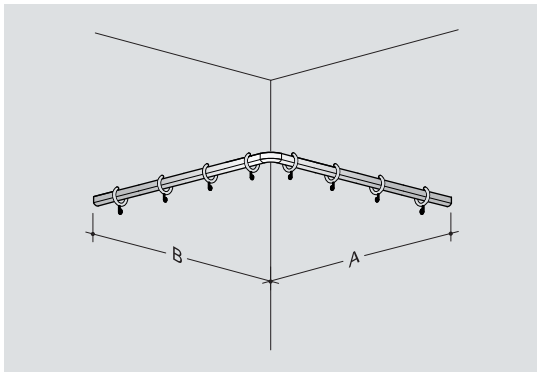

Reggitenda angolare
Corner shower curtain rail
Barre de rideau de douche a coin
Duschvorhangstange L-Form
Barra de cortina en ángulo
Hoekvormige Douchegordijnhouder

ART.	A	B	n°
CAP.436.0000. ..	800 (815)*	800 (815)*	16

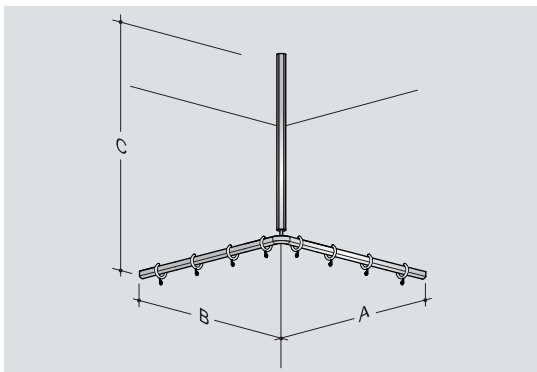

Reggitenda angolare con supporto a soffitto
Corner shower curtain rail with ceiling support
Barre de rideau de douche a coin avec support plafond
Duschvorhangstange L-Form mit Deckenabhängung
Barra de cortina en ángulo con soporte a techo
Hoekvormige Douchegordijnhouder met plafondsteun

ART.	A	B	C	n°
CAP.436.000B. ..	800 (815)*	800 (815)*	440 (458)*	16
CAP.436.000BA. ..	900 (915)*	900 (915)*	440 (458)*	18
CAP.436.000BB. ..	1000 (1015)*	1000 (1015)*	440 (458)*	20
CAP.436.000BC. ..	1200 (1215)*	1200 (1215)*	440 (458)*	24
CAP.436.000BD. ..	1500 (1515)*	1500 (1515)	440 (458)*	30

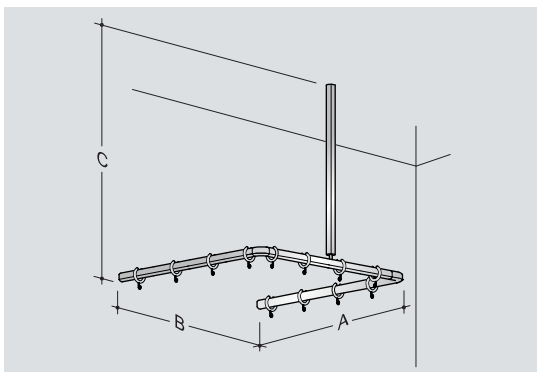

Reggitenda su tre lati con supporto a soffitto
Three-sided shower curtain rail with ceiling support
Barre de rideau de douche sur trois côtés avec support plafond
Duschvorhangstange U-Form mit Deckenabhängung
Barra de cortina en "U" con soporte a techo
U-vormige Douchegordijnhouder met plafondsteun

ART.	A	B	C	n°
CAP.437.0000. ..	800 (815)*	800 (830)*	440 (458)*	24
CAP.437.000A. ..	1000 (1015)*	1000 (1030)*	440 (458)*	30

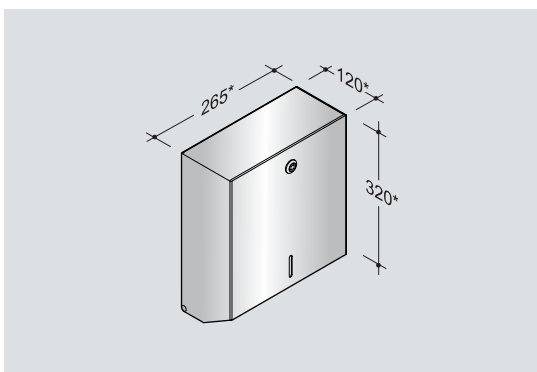

Portasalvietta
Paper towel dispenser
Distributeur d'essuie-mains papier
Papierhandtuchspender
Dispensador de toallas de papel
Handdoekhouder

ART.
CAP.498.0000. ..

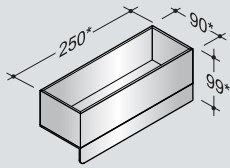
PROGRAMMA CAP
R

Mensola portaoggetti
 Bathroom shelf
 Tablette porte-objet
 Utensilienablage
 Estante porta-objetos
 Kleine tablethouder

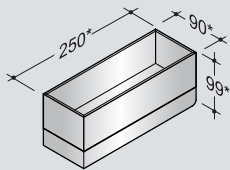
ART.
CAP.492.000R. ..
L

Mensola portaoggetti
 Bathroom shelf
 Tablette porte-objet
 Utensilienablage
 Estante porta-objetos
 Kleine tablethouder

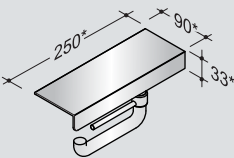
ART.
CAP.492.000L. ..
L

Portarotolo
 toilet roll holder
 Porte-papier
 Papierrollenhalter
 Portarrollos
 WC Rolhouder

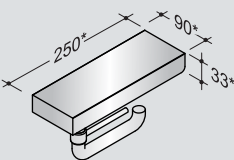
ART.
CAP.481.000L. ..
R

Portarotolo
 toilet roll holder
 Porte-papier
 Papierrollenhalter
 Portarrollos
 WC Rolhouder

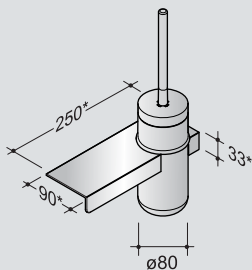
ART.
CAP.481.000R. ..
R

Portascopino
 WC brush set
 Ensemble brosse WC
 WC-Bürstengarnitur
 Escobillero
 Toiletborstel

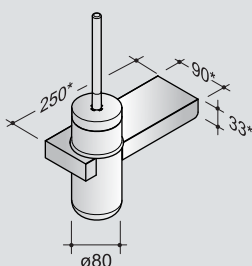
ART.
CAP.486.000R. ..
L

Portascopino
 WC brush set
 Ensemble brosse WC
 WC-Bürstengarnitur
 Escobillero
 Toiletborstel

ART.
CAP.486.000L. ..

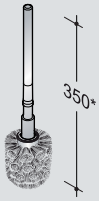
PROGRAMMA CAP

Scopino di riserva con impugnatura
Spare WC brush with handle
Brosse WC de réserve avec poignée
Ersatzbürste mit Stiel
Escobilla de reserva con mango
Reserveborstelkop met handgreep

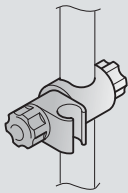
ART.
4CN.486.00SR. ..

Reggisoffione
Shower head holder
Curseur de douchette
Brausehalter
Soporte ducha
Douchekophouder

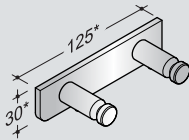
ART.
CAP.487.000R. ..

Appendiabiti
Cloth hook
Crochet
Wandhaken
Percha
Kapstok

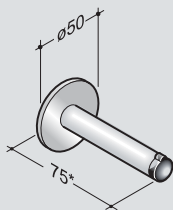
ART.
CAP.488.0000. ..

Appendiabiti fermaporta
Doostop-cloth hook
Crochet-butoir
Wandhaken mit Stopper
Tope-percha
Kapstok – deurstop

ART.
CAP.562.0000. ..

Anello reggitenda
Curtain ring
Anneau pour rideau de douche
Vorhangring
Anillas para cortina
Gordijnring

ART.
4CN.0AN.0002. ..

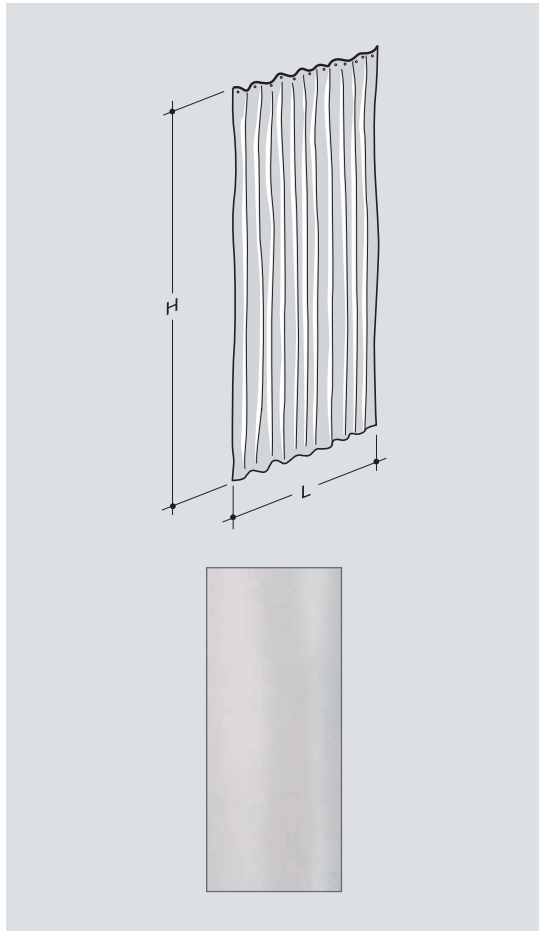

Lampadina
Bulb
Ampoule
Lampe
Bombilla
Bloembollenteelt

ART.
4CN.407.0000.00

PROGRAMMA CAP

Tenda ignifuga per doccia
 Fireproof shower curtain
 Rideau de douche ignifuge
 Duschvorhang, feuerfest
 Cortina de ducha ignifuga
 Brandwerend douchegordijn

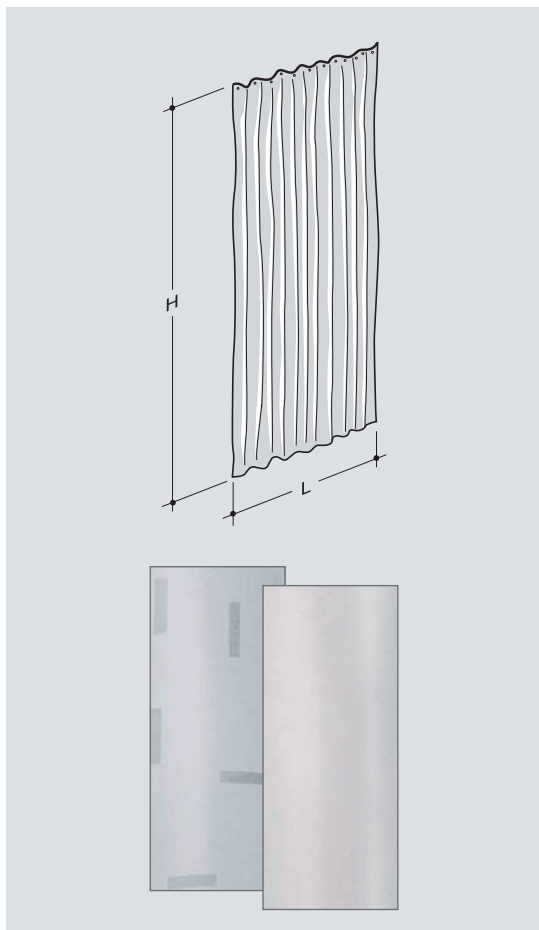
ART.	L	H	
4CN.0SC.000B. ...	1200	2000	Art. CAP.429.0000, CAP.429.000A, CP.429.000B, CAP.436.000*, CAP.436.000B*, CAP.436.00BA*, CAP.436.00BB*
4CN.0SC.000C. ...	1800	2000	Art. CAP.429.000C, CAP.429.000D, CAP.429.000E, CAP.436.0000, CAP.436.000B, CAP.436.00BC*, CAP.436.00BD*, CAP.437.0000*, CAP.437.000A*



Tenda impermeabile per doccia
 Waterproof shower curtain
 Rideau de douche imperméable
 Duschvorhang
 Cortina de ducha impermeabile
 Douchegordijn

ART.	L	H	
CAP.0SC.00AE. ...	1200	750	Art. CAP.435.000R, CAP.435.000L
4CN.0SC.00BE. ...	1200	2000	Art. CAP.429.0000, CAP.429.000A, CP.429.000B
4CN.0SC.00CE. ...	1800	2000	Art. CAP.429.000C, CAP.429.000D, CAP.429.000E, CAP.436.00BC*, CAP.436.00BD*, CAP.437.0000*, CAP.437.000A**
4CN.0SC.00DE. ...	2000	2000	Art. CAP.436.0000, CAP.436.000B,
4CN.0SC.00EE. ...	2400	2000	Art. CAP.436.00BA, CAP.436.00BB

* 2 PEZZI
 ** 3 PEZZI

* 2 PIÈCES
 ** 3 PIÈCES

* 2 PIÈCES
 ** 3 PIÈCES

* 2 STÜCK
 ** 3 STÜCK

* 2 PIEZAS
 ** 3 PIEZAS

* 2 STUKS
 ** 3 STUKS

PROGRAMMA CAP



ARCON

Rosselló, 21. 08029 Barcelona • Tel.: 936 002 002 Fax.: 936 002 006 • info@arcon.es

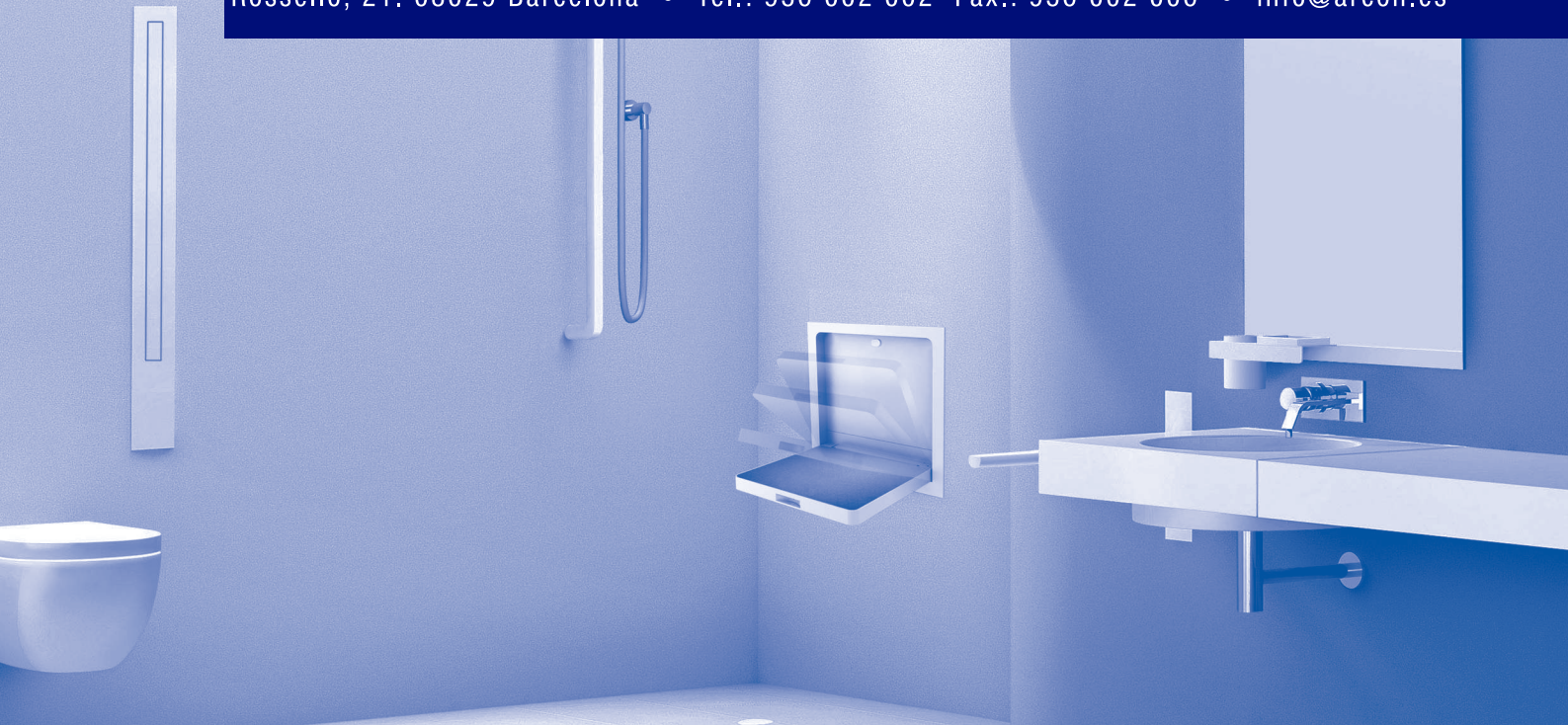

www.arcon.es